

**MODELS**

**EES 30  
EES 40  
EES 52**

**EES 66  
EES 80  
EES 120**

# **INSTALLATION AND USER INSTRUCTION**

**UNITED KINGDOM / IRELAND**

**ELECTRIC WATER HEATERS**



<b>1.</b>	<b>GENERAL .....</b>	<b>4</b>
1.1	Description of the apparatus.....	4
1.2	Technical safety devices.....	4
1.2.1	Thermostat .....	4
1.3	Technical description .....	5
1.3.1	Dimensions EES 30 en EES 40 .....	5
1.3.2	Dimensions EES 52, EES 66, EES 80 en EES120 .....	6
<b>2.</b>	<b>FOR THE INSTALLER.....</b>	<b>7</b>
2.1	Installation instructions .....	7
2.1.1	Installation .....	7
2.1.2	Water connection.....	7
2.1.3	Electrical connection.....	7
2.2	Putting into operation.....	8
2.2.1	Filling of the heater .....	8
2.2.2	Putting into operation.....	8
2.2.3	Puttin out of operation .....	8
2.2.4	Temperature control.....	8
2.3	Maintenance .....	8
2.3.1	Sacrificial anode .....	8
2.3.2	Decalcification .....	8
2.4	Measures to be taken at moments of failures.....	8
2.5	Safety thermostat .....	9
2.6	Water temperature not right.....	9
2.6.1	Warm water temperature too high .....	9
2.7	Probability of a water leakage .....	9
2.8	Important advises .....	9
<b>3.</b>	<b>FOR THE USER.....</b>	<b>10</b>
3.1	Instructions for use .....	10
3.1.1	Advice .....	10
3.1.2	Filling of the heater .....	10
3.2	Putting into operation.....	10
3.3	Use .....	10
3.4	Putting out of operation .....	10
3.5	Maintenance .....	10
3.6	Measures in case of failure.....	11
<b>4.</b>	<b>WARRANTY .....</b>	<b>12</b>
4.1	General warranty .....	12
4.2	Tank warranty .....	12
4.3	Conditions of installation and use.....	12
4.4	Exclusions .....	12
4.5	Extent of the warranty.....	12
4.6	Claims.....	12
4.7	No obligations for A.O. Smith other than those specifi ed here. ....	12

## **1. GENERAL**

### **1.1 Description of the apparatus**

The construction and equipment of the electric storage heater meet the European standards for electric household apparatus (IEC 335-1 and IEC 335-2-63 / EN60335-2-21). Thus, the heater is in conformity with the European directives of electric household apparatus, implying the authority to bear the CE-mark. The heater is appropriate for a working power of 8 bar. The tank is of steel plate and has got a glasslined coating, in its interior. Simultaneously, the tank is provided with two sacrificial anodes, as an additional protection against corrosion. A thick FFC insulating layer, surrounded by a steel casing is preventing it from an unnecessary loss of heat. As soon as the heater will be completely filled with water, it will continually be under the pressure of the water supply. Draining hot water, the heater will immediately be refilled with cold water. A good transmission of heat is given by the use of incolony heating elements.

Additional comfort can be created by making use of a circulation pipe with the corresponding pump. The connection of the above pipe will have to take place at the cold water pipe.

### **1.2 Technical safety devices**

#### **1.2.1 Thermostat**

The heater is provided with one or two regulating thermostats with a setting range between 32 °C and 82 °C. Further on, the heater is equipped with one safety thermostat, being set at 95 °C.

### 1.3 Technical description

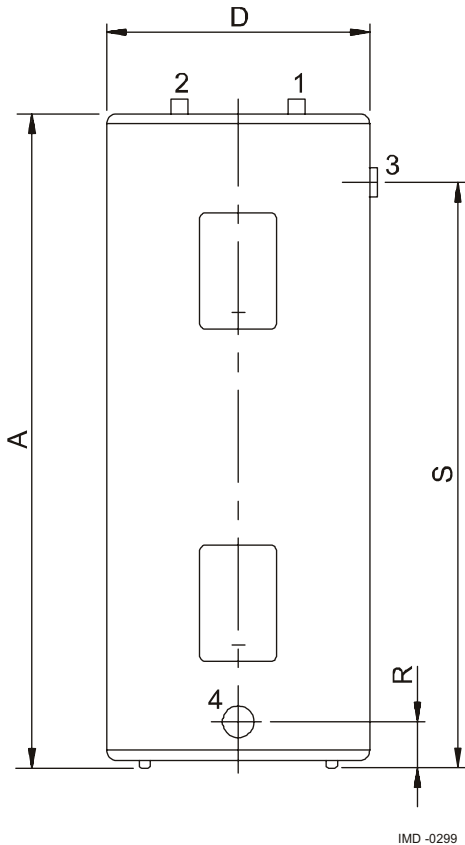

IMD -0299

EES 30, ...120

#### 1.3.1 Dimensions EES 30 en EES 40

TYPE		EES 30	EES 40
Total height	A	930	1110
Diameter of the apparatus	D	520	520
Height of drain tap	R	95	95
Height of T&P plug	S	715	970
Connection cold water	1	3/4" -14 NPT	3/4" -14 NPT
Connection hot water	2	3/4" -14 NPT	3/4" -14 NPT
Connection T&P plug	3	3/4" -14 NPT	3/4" -14 NPT
Connection drain tap	4	3/4" -14 NPT	3/4" -14 NPT
Tankage		115	155
Number of elements		2	2
Capacity (220 V)		2,5	2,5
Capacity (240 V)		3,0	3,0
Heating time up to 60°C (220/240 V)*		158/133	208/175
Heating time up to 40°C (220/240 V)*		94/79	125/105
Draining tap capacity at 60°C first hour (220/240)**		135/143	165/173
Draining tap capacity continuous, at 60°C (220/240)**		44/52	44/52
Draining tap capacity at 40°C first hour (220/240)**		224/238	275/289
Draining tap capacity continuous, at 40°C (220/240)**		73/87	73/87
Weight		51	61

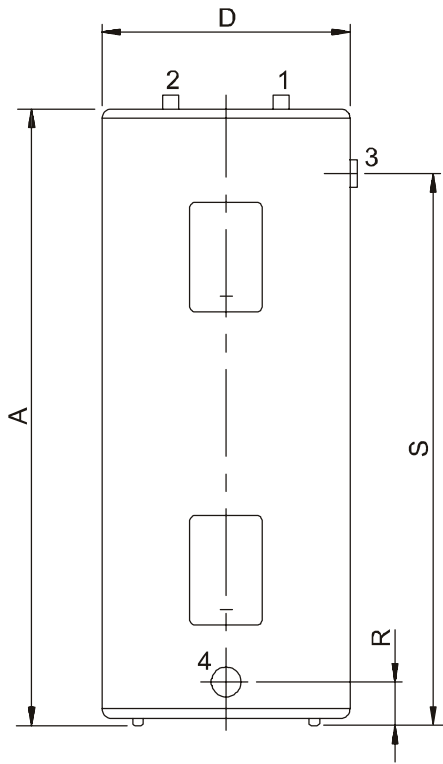

IMD -0299

EES 30, ...120

### 1.3.2 Dimensions EES 52, EES 66, EES 80 en EES120

TYPE			EES 52	EES 66	EES 80	EES 120
Total height	A	mm	1370	1530	1540	1620
Diameter of the apparatus	D	mm	510	520	570	710
Height of drain tap	R	mm	95	95	95	110
Height of T&P plug	S	mm	1210	1360	1330	1385
Connection cold water	1	∅	3/4" -14 NPT	3/4" -14 NPT	3/4" -14 NPT	3/4" -14 NPT
Connection hot water	2	∅	3/4" -14 NPT	3/4" -14 NPT	3/4" -14 NPT	3/4" -14 NPT
Connection T&P plug	3	∅	3/4" -14 NPT	3/4" -14 NPT	3/4" -14 NPT	3/4" -14 NPT
Connection drain tap	4	∅	3/4" -14 NPT	3/4" -14 NPT	3/4" -14 NPT	3/4" -14 NPT
Tankage		lt.	190	250	300	450
Number of elements		stuks	2	2	2	2
Capacity (220 V)		kW	2,5	2,5	2,5	2,5
Capacity (240 V)		kW	3,0	3,0	3,0	3,0
Heating time up to 60°C (220/240 V)*		min	255/214	343/289	416/350	625/525
Heating time up to 40°C (220/240 V)*		min	153/129	206/173	250/210	375/315
Draining tap capacity at 60°C first hour (220/240)**		lt/uur	201/209	244/252	286/294	407/415
Draining tap capacity continuous, at 60°C (220/240)**		lt/uur	44/52	44/52	44/52	44/52
Draining tap capacity at 40°C first hour (220/240)**		lt/uur	335/349	406/420	447/491	679/693
Draining tap capacity continuous, at 40°C (220/240)**		lt/uur	73/87	73/87	73/87	73/87
Weight		kg	69	89	103	161

## 2. FOR THE INSTALLER

### 2.1 Installation instructions

The heater will not be installed but in spaces meeting the national and local regulations. These spaces will be frost protected.

#### 2.1.1 Installation

The installation will be effected according to the current general and local regulations of the electric and water works, and that, by an authorised installer.

#### 2.1.2 Water connection

The max. admissible working pressure of the heater will amount to 8 bar. On the cold water side, the heater will have to be provided with a stop valve, as well as an approved inlet combination. The overpressure side, of the inlet combination, will have to be connected to an open water discharge. Insulating long pipes, will prevent from waste of energy.

#### 2.1.3 Electrical connection

The electric installation will always be effected by an authorised installer, as well as according to the general and current regulations of the electricity works. This heater will have to be provided with a main switch, as soon as a fixed connection is involved.

#### **Warning: Earth the equipment**

In the case of schema B with night current option, connect the day current connection to L1, connect the night current connection to L2 and remove the jumper (dotted).

- 1) Connection current at day tariff
- 2) Safety thermostat of two poles
- 3) Regulating thermostat provided with a selector switch
- 4) Heating elements
- 5) Regulating thermostat
- 6) Connection with option night current rate

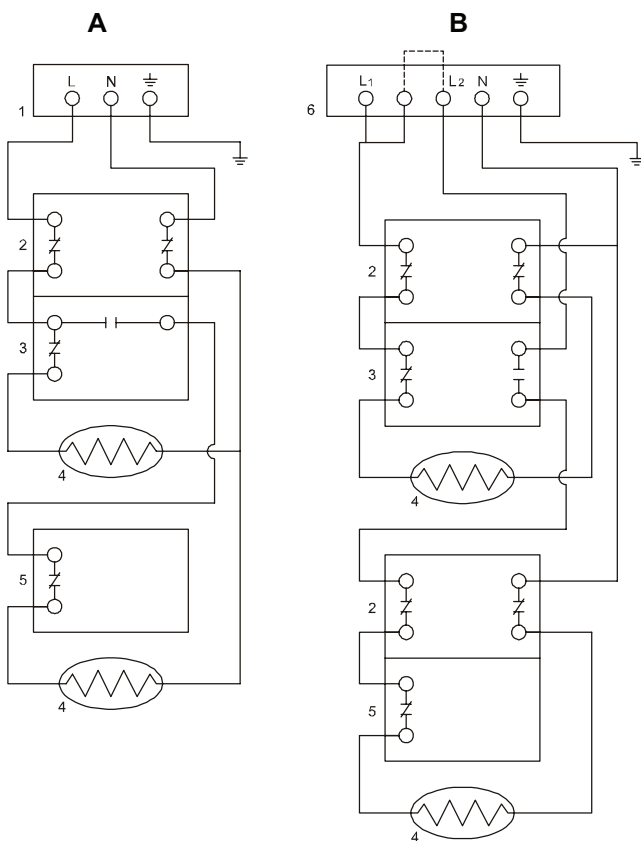

A	B
Wiring diagram for non-simultaneous use of heating elements	Wiring diagram for non-simultaneous use of night power supply.
Scope: EES30-EES40-EES52 EES66-EES80-EES 120	Scope: EES30-EES40-EES52 EES66-EES80-EES 120
Power supply: 220-240 V 50-60 Hz IP40	Power supply: 220-240 V 50-60 Hz IP 40

## 2.2 Putting into operation

### 2.2.1 Filling of the heater

1. Install the drain tap and check whether it is closed.
2. Open the cold water tap leading to the heater and the rest of the taps of warm water outlet, for ventilation. The apparatus will be filled, as soon as water is flowing out of every outlet.
3. Again, turn off all the taps of warm water outlets.

### 2.2.2 Putting into operation

1. Check, whether the heater is filled with water and whether all electric connections leading to it are actually well carried out.
2. Check whether the cold water inlet is open.
3. Open the covering plate at the front remove the insulation to be found thereunder. Now, the regulating thermostats will be accessible. And can subsequently be adjusted at the demanded temperature, by turning the selector switch by a screwdriver.
4. Set the demanded temperature, on the regulating thermostat (see table). The temperature adjusted ex works is of 60°C.

Temperature in °F	Temperature in °C
90	32
100	38
110	43
120	49
130	54
140	60
150	66

5. Replace the insulation and put back the covering plate.
6. With a fixed connection, switch on the main switch or, otherwise, put the plug into the socket. Thereon, the apparatus will be in operation and start to work, automatically.

### 2.2.3 Puttin out of operation

1. For short periods: Remove the plug from the sockey or, if the connection is fixed, switch off the main switch.
2. For longer periods, it will be recommendable to not only act according to the advises sub 1, but also shut of the water supply pipe and, as soon as the heater will be cooled off, let out the water (fitting an outlet pipe on the drain tap and open it), in view of the danger of frost. (Open the nearest warm water drain taps, as well, so that the tank can be ventilated). Whenever the heater will have to be emptied completely, detach it and let it slope in the direction of the drain tap.

### 2.2.4 Temperature control

The apparatus is under the pressure of the water supply (max. 8 bar). There will be supplied the same quantity of cold water as the one used up of hot water. This implies that in the moment of showing the thermostat a temperature being inferior to the set one, the electric circuit will be closed, making an electric current pass through the heating element. After having reached the demanded temperature, the thermostat will interrupt the contact again. High water temperature will involve a calcium precipitation, inside the heater. Therefore, it is recommended to maintain the adjusted temperature of 60 °C, so that less furring will occur. Moreover, a built in safety thermostat will completely interrupt the current supply, at a water temperature of 95 °C.

## 2.3 Maintenance

At least once a year, the heater will have to be checked and cleaned by an expert, to guarantee its good function.

### 2.3.1 Sacrificial anode

The service life of the anodes is determined by the quality and quantity of the water flowing through. That is why iet will be recommendable to have the anodes inspected, every year.

1. Turn off the cut-off cock of the feed pipe of cold water.
2. Open the nearest warm water tap, to eliminate the water pressure of the heater and the water conduit.
3. Loosen the anode by the right key.
4. Inspect and replace it, whenever used off by 60%.
5. Screw in the anode to be waterproof.

If the anode must by replaced, make sure that the new one always will be of exactly the same type. This can be checked by the type of the heater, as well as by the complete serial number.

### 2.3.2 Decalcification

The lyme forming is a sequel of the quality and the dmand of the water. Besides, lyme forming will always be of a higher degree with high water temperatures than with low ones. Therefore, it is recommended to adjust the temperature at 60 °C, so that the degree of calcium precipitation can be kept at a low rate. Decalcification will have to be done by using appropriate means. If you need more detailed information thereon, the relevant instructions are available.

## 2.4 Measures to be taken at moments of failures

Whenever there is a failure, the items given below will have to be checked before calling a trouble-shooting service.

## 2.5 Safety thermostat

Every heater has got a number of safety thermostats interrupting the electric circuit, at high water temperatures (95°C). These safety thermostats cannot be reset but after a decrease of the temperature by 20°C. Subsequently, the regulating thermostat will be checked: if it has been adjusted at a high temperature, the thermostat will probably be broken and must be replaced.

## 2.6 Water temperature not right

1. Check the adjustment of the regulating thermostat.
2. Check whether there are leakage's and/or open taps.
3. Check whether the wiring is still correctly connected.
4. It's possible that the consumption of hot water is higher than it had been calculated, originally.
5. Inspect whether the cold water inlet pipe has got the right position.

### 2.6.1 Warm water temperature too high

Check whether the regulating thermostat is set too high.

## 2.7 Probability of a water leakage

1. Check whether the drain tap is completely shut.
2. Check whether the water connections are waterproof.

## 2.8 Important advises

The heater must **NEVER** be put into operation, with the cold water supply turned off.

The heater must not be under pressure nor voltage, in the course of a maintenance.

### 3. FOR THE USER

#### 3.1 Instructions for use

##### 3.1.1 Advice

Installing and putting into operation the heater for the first time will have to be done by an authorised installer.

##### 3.1.2 Filling of the heater

Operating procedure:

1. Check whether the heater is filled with water.
2. Open the cold water tap in the direction of the heater, as well as all the taps of hot water drains, for the purpose of ventilation. The heater will be filled, as soon as cold water is flowing, at every drain tap.
3. Again, turn off all the taps of hot water drain taps.

#### 3.2 Putting into operation

Operating procedure:

1. Check whether the heater is filled with water.
2. Turn on the main switch, whenever there is a fixed connection or put the plug into the socket.

#### 3.3 Use

The heater is under the pressure of the water supply (max. 8 bar). The quantity of cold water being supplied, will exactly correspond to the one of the consumption of hot water. The regulating thermostat will switch on the electric supply, automatically. This implies that the electric circuit will be shut and heat supplied to the water, whenever the temperature is inferior to the demanded one. The electric circuit will be interrupted again, at the moment the demanded temperature will be reached.

Temperature in °F	Temperature in °C
90	32
100	38
110	43
120	49
130	54
140	60
150	66

In view of the limitation of the precipitation of calcium, it will be recommendable to adjust the temperature at 60 °C. Besides, a safety thermostat will be fitted, interrupting completely the electric circuit, the water temperature having reached 95 °C. After this temperature will have fallen by 20 °C, the thermostat can be reset, again. In the case of another intervention of the safety thermostat, with the regulating thermostat being adjusted at a high temperature, this last one will have to set at a lower temperature. If there will still be another intervention of the safety thermostat, the regulating one will probably be out of order.

#### 3.4 Putting out of operation

Operating procedure:

1. For short periods: Remove the plug from the socket or, with a fix connection, turn off the main switch.
2. For longer periods it will be recommendable, in view of the danger of frost, not only take the measures indicated sub 1, but also turn off the water supply pipe and, after the heater will have cooled down, drain the water (connect a drain hose on the drain tap and open it). Also, open the nearest hot water tap drain, so that the tank can be ventilated. If there is the intention to totally empty the heater, uncouple it and let it slope in the direction of the drain tap.

#### 3.5 Maintenance

Regularly test the inlet combination by discharging it (activate the discharge button). The water must come out of it as a thick jet: Check, whether the drain pipe is open. It will be recommendable to sign a contract, based on a maintenance, once a year.

When ordering spare parts, it will be necessary to specify the type of apparatus and the complete serial number. Thereby, the data of the spare parts can be determined.

##### Important advises:

**The heater must NEVER be put into operation, with the cold water supply being shut off. In the course of maintenance, the heater must not be under tension.**

### 3.6 Measures in case of failure

<b>Trouble</b>	<b>Cause</b>	<b>Measures to be taken</b>
Insufficient or no hot water at all	The temperature is set too low	Adjust the regulating thermostat higher
	The safety thermostat is interrupting the electric circuit	Press the reset button
	There is no hot water supply left	Reduce the hot water consumption. Admit the necessary heating time
	The plug is out of the socket	Put the plug into the socket
	The cause cannot be determined	Turn off the main switch and/or remove the plug from the socket
Leakage	Insufficient packing of the water connection (threaded connection)	Tighten the threaded connections
	Leakage due to other water apparatus or pipes, sited in the neighbourhood	Find the cause

## 4. WARRANTY

If you fill in the certificate correctly and in time, it grants the owner of the boiler, supplied by A.O. Smith Water Products Company B.V., Veldhoven, The Netherlands (after this 'A.O. Smith'), the right to the guarantee that is described below.

### 4.1 General warranty

If, within one year from the original installation date, after investigation and exclusive evaluation by A.O. Smith, a boiler delivered by A.O. Smith turns out to have a part, with the exception of the tank, that is not properly functioning as a result of manufacturing or material faults, A.O. Smith will replace or repair this part.

### 4.2 Tank warranty

If (an EES 30 to 120), within 5 years of the original installation date, after investigation and exclusive evaluation by A.O. Smith, a boiler delivered by A.O. Smith turns out to have a steel glass-lined tank that is leaking as a result of rust or corrosion from the water side, A.O. Smith will replace the whole boiler by a completely new one of similar size and quality.

The replacement boiler will have a warranty that will be valid for the remaining period of the warranty for the original boiler delivered. Notwithstanding the provisions in Article 2, the warranty term will be reduced to one year after the original installation date if unfiltered or softened water is flowing through the boiler or left in it.

### 4.3 Conditions of installation and use

The warranty referred to in Articles 1 and 2 only applies if the following conditions are met:

- a) that the boiler is installed according to the installation instructions of A.O. Smith for the specific model, as well as according to the local and national installation and building regulations, instructions and rules;
- b) that the boiler will remain installed in the original installation position;
- c) that only drinking water is used, which is allowed to circulate freely at all times (a separately installed heat exchanger is requisite for the heating of saline or corrosive water);
- d) that the tank has been defurred to remove harmful scale deposits by means of periodic maintenance;
- e) that the boiler-water temperatures do not exceed the maximum settings of the thermostats that are part of the boiler;
- f) that the water pressure and/or heat load do not exceed the maximum values indicated on the boiler's identification plate;
- g) that the boiler has not been installed in a corrosive atmosphere or environment;
- h) that the boiler has been provided with an inlet combination, approved by an authorised body, of sufficient capacity, not greater than the operating pressure indicated on the boiler, and, if applicable, with a temperature and pressure relief valve, also approved by an authorised body, which has been mounted according to the installation instructions of A.O. Smith that apply to the specific boiler model, as well as according to the local and national instructions, regulations and rules;
- i) that the anodes are replaced and renewed if and when they have 60 % or more wear.

### 4.4 Exclusions

The warranty referred to in Articles 1 and 2 does not apply:

- a) for equipments that are not used for domestic use, guarantee on the tank for one year after the initial installation date applies, with the conditions shown in article 2.
- b) if the boiler has been damaged by an external cause;
- c) in case of abuse, neglect (including freezing), modification, incorrect and/or deviating use of the boiler and if attempts have been made to repair leaks;
- d) if contamination or other impurities were allowed to flow into the tank;
- e) if the conductivity of the water is less than 150 microSiemens and/or the hardness of the water is less than 6°DH;
- f) if unfiltered, recirculated water flows through or is stored in the boiler
- g) if the owner has attempted to repair a defective boiler himself.

### 4.5 Extent of the warranty

A.O. Smith's commitments pursuant to the warranty provided are confined to the delivery free of charge of the boiler to be replaced or any parts thereof ex the Veldhoven warehouse. Any costs involved with transport, labour, installation or any other capacity connected to the replacement cannot be charged to A.O. Smith.

### 4.6 Claims

A claim based on the warranty provided shall be deposited with the dealer from whom the boiler was purchased or any other dealer who sells products manufactured by A.O. Smith. The examination of the boiler as referred to in the Articles 1 and 2 will take place in an A.O. Smith laboratory.

### 4.7 No obligations for A.O. Smith other than those specified here.

In relation to its boilers or else the boilers (or parts or components thereof) supplied for replacement, no warranty or guarantee is given by A.O. Smith other than the warranty given here. A.O. Smith will not be held liable for any damage to property or persons under the warranty given or in any other way caused by a boiler it has supplied (parts or components or the steel glass lined tank) (for replacement).

This warranty applies to the following models:

EES 30	EES 66
EES 40	EES 80
EES 52	EES 120







