

MODELS

**DRE 52
DRE 80
DRE 120**

INSTALLATION AND USER INSTRUCTIONS

england

HOT WATER STORAGE DEVICES

Read this manual carefully

Warning

Read this manual carefully before using the device. Not reading this manual and not following the instructions in this manual may lead to personal injuries and damage to the device.

Copyright © 2009 A.O. Smith Water Products Company

All rights reserved.

Nothing from this edition may be copied, reproduced and/or made public by means of press, photocopying or in any other way without the prior written permission of A.O. Smith Water Products Company.

A.O. Smith Water Products Company reserves the right to change the specifications as mentioned in this manual.

Trademarks

All brand names mentioned in this manual are registered trademarks of the respective suppliers.

Liability

A.O. Smith Water Products Company does not accept any liability for claims of third parties as a result of incompetent use other than mentioned in this manual and in conformity with the General Terms and Conditions as filed with the Chamber of Commerce.

For further information see the General Terms and Conditions. These can be obtained from us free of charge.

Although utmost care has been taken in ensuring a correct and, where necessary, complete description of the relevant parts, the manual may contain errors and some things may be unclear.

Should you still discover faults or things which are unclear, please inform us about this. It helps us to further improve the documentation.

Additional information

If you have any remarks or questions concerning specific subjects related to the device, please do not hesitate to contact:

A.O. Smith Water Products Company
P.O. Box 70
5500 AB Veldhoven
The Netherlands

Telephone: (free) 0800 - AOSMITH
0800 - 267 64 84

General: +31 40 294 25 00

Fax: +31 40 294 25 39

E-Mail: info@aosmith.nl

Website: www.aosmithinternational.com

For problems with respect to connections to electricity and water supplies, please contact the supplier/installation engineer of your installation.

TABLE OF CONTENTS

1.	GENERAL.....	4
1.1	Device Description.....	4
1.2	Regulation and Safety	5
1.2.1	Boil Dry Protection	7
1.2.2	Checking the Float Switch	8
1.3	Technical description	9
1.4	Technical Data	10
2.	FOR THE INSTALLER	12
2.1	Installation procedures.....	12
2.1.1	General Installation.....	12
2.1.2	Water Connections	12
2.1.3	Electrical Connection.....	12
2.1.4	Electrical Diagrams.....	13
2.2	Putting into operation.....	17
2.2.1	Filling the Device	17
2.2.2	Putting Into Operation.....	17
2.2.3	Putting out of Operation.....	17
2.2.4	Temperature Regulation	18
2.3	Maintenance	18
2.3.1	Sacrificial anode	18
2.3.2	Descaling.....	18
2.4	Steps When There is a Fault	18
2.4.1	Water Temperature Not Good.....	19
2.4.2	Presumed Water Leakage	19
2.4.3	Fault Table	20
2.5	Spare Parts.....	20
3.	FOR THE USER	21
3.1	Instructions for Use.....	21
3.1.1	Filling the Device	21
3.1.2	Putting into operation.....	21
3.1.3	Use	21
3.1.4	Putting out of operation.....	22
3.2	Maintenance	22
3.3	Faults	22
4.	WARRANTY	23
4.1	General Warranty.....	23
4.2	Tank Warranty.....	23
4.3	Conditions of installation and use	23
4.4	Exclusions.....	24
4.5	Extent of the warranty.....	24
4.6	Claims.....	24
4.7	No obligations for A.O. Smith other than those specified here.	24

1. GENERAL

1.1 Device Description

The structure and equipment for this electrical heating device are in accordance with the European standard for electrical household devices (EN 60335-1:2002 + A11:2004 + A1:2004 + A12:2006 + A2:2006 en EN 60335-2-21:2003 + A1:2005) The device thus meets the European Directive for Electrical Household Devices and has the right to bear a CE mark.

The device is suitable to be used with an operating pressure of up to 8 bar (= 800 kPa). The tank is made of steel plate, which has a glass lined coating

on the inside. The tank is also provided with two sacrificial anodes to give extra protection against corrosion. A thick CFC free polyurethane insulation layer, covered with a steel casing, prevents unnecessary heat loss. The device is fully filled with water and continually starts under water pipe pressure. When hot water is drawn off from the device, it is immediately topped up with cold. Incoloy heating elements are used for good transfer of heat.

To create extra comfort in case of long pipelines, circulating piping with a circulating pump may be connected to the piping. The circulating pipeline can be connected to the cold-water supply.

1.2 Regulation and Safety

For clarification see the diagram below:
(the image is an extract from the electrical diagram further on)

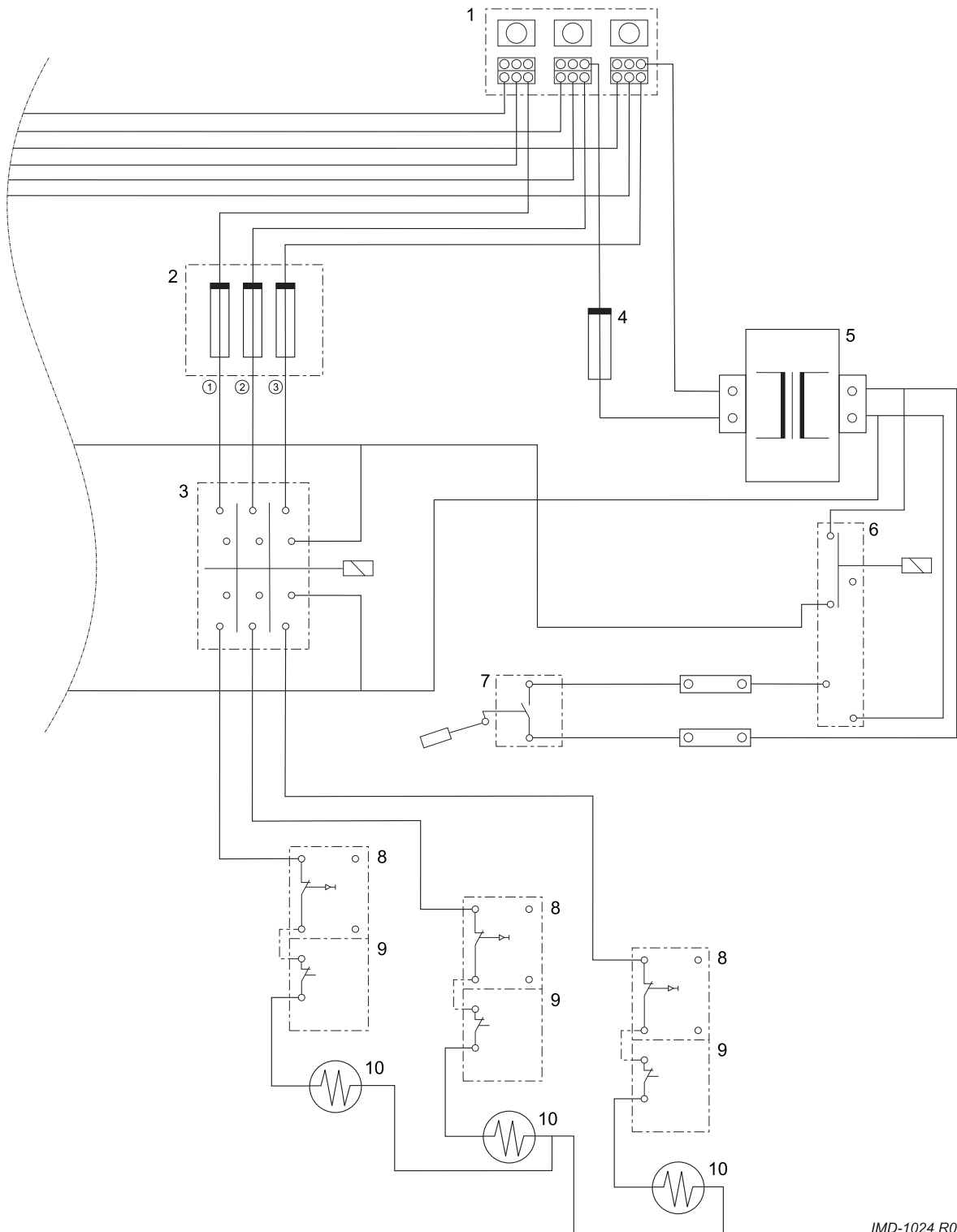

Fig. 1 - regulation and safety

IMD-1024 R0

3 relays (3) and a control current transformer (5) are fed from the main connection block (1). The main circuit is protected by 30 Amp T fuses. The transformer (400V to 24V) is primarily secured with T0,2 A (4). A boil dry protection mechanism (in the form of a float switch) (7) is included in the 24V current control circuit. (The float switch is indicated diagrammatically. See boil dry protection further on for more precise explanation) The control current circuit is closed if there is water in the device (float switch). In this case an auxiliary relay (6) is used which in turn switches the relay (3). The relays determine whether the electrical elements are fed.

The elements are fed via the relay (3). The wire goes to the maximum thermostat (8) via the relays (2). The maximum thermostat has a reset button. The output from the maximum thermostat goes to the regulating thermostat (9). The element (10) is fed from the regulating thermostat.

During normal operation the regulating thermostat (9) switches the element (10) on and off. If a temperature of above 93°C occurs on an element the maximum thermostat (8) locks the element. In order to put the element back into operation the reset button of the maximum thermostat must be pressed in. The temperature must have dropped by approximately 20°C before the maximum thermostat can be reset.

If the temperature of the water above in the tank exceeds 98°C for any reason, the combined temperature and pressure safety device (T&P valve) will open.

The safety control circuit will be interrupted if the water level drops to below the float switch (7) or if the device is switched on while empty.

The device is then switched off completely. This is to prevent the elements coming into operation while there is insufficient water present in the device (boil dry protection).

The safety fuses, 30 Amp T for 600 V can be ordered retrospectively from A.O. Smith.

1.2.1 Boil Dry Protection

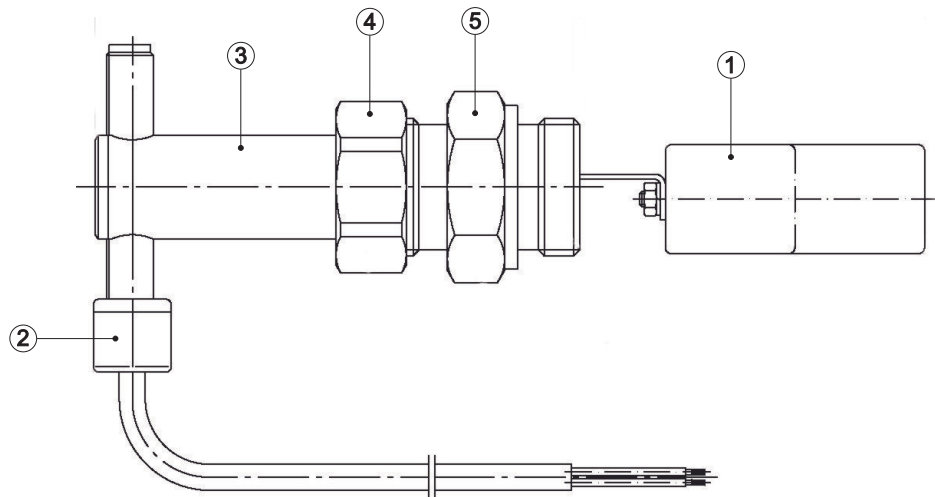

Fig. 2 - float switch

The boil dry protection mechanism consists of a float switch which monitors the water level approximately halfway up the tank above the elements. If there is insufficient water present in the tank, then the float (1) hangs down. If the tank is filled with water then the float is moved upwards by the water. In the electrical diagram the float switch is reproduced diagrammatically. The actual process is as follows: the float arm moves a magnet with respect to the reed-contact (2) which is located in the black plastic tube at the end of the float switch. The movement of the magnet changes the magnetic field and the reed-contact is closed.

The exposure height (3) of the reed contact is very important.

This is 14 mm. This setting may not be changed!

Explanation:

With an exposure height of 14 mm the switch point is approximately halfway along the stroke of the float.

If the exposure height is set lower, then the switch point shifts upwards. If the exposure height is too small the contact will no longer connect even if the float

is completely above it. In this case the device will not come into operation. If the exposure height is set lower than 14 mm, then the switch point shifts downwards. This means that the contact will already connect upon a small upwards movement of the float. If the exposure height is set too high then the contact is permanently closed and the safety mechanism does not work. This means that the elements can come into operation without there being sufficient water present in the device. This will lead to the elements burning out in a very short time and short circuit and leakage. So never change the exposure height.

The reed contact and the float must always be vertical. The arrow on the clamping plate on the front must point upwards. The float switch is secured in the tank with nut (5). By loosening nut (4) the float switch can be set vertically. Nut (4)

is sealed with an o-ring with respect to nut (5). The float switch must be taken out of the device as a complete unit for checking or replacement. (The float cannot be passed through the opening in nut (5).) For this purpose the device thus has to be drained.

1.2.2 Checking the Float Switch

Switch off the feed voltage and remove the fuses from the elements. In this way the control circuit can be tested without the elements being put into operation. Drain the device until the water is definitely below the float switch. If desired the float switch can now be removed for visual inspection. Check the resistance of the contacts with a multimeter and check whether the switch point is situated approximately halfway along the stroke of the float. (For new contacts this resistance is between 1 and 1.5 Ohms). Screw the float switch back into the tank and place it vertically. Check the exposure height. Close the door and connect the feed voltage. The safety relays must not come in. (The tautening and release of the safety relays is clearly audible.) Now allow water to flow into the device. If the water presses the float upwards, the float switch closes the control circuit and the safety relays will tauten. Then drain the device once again. The lowering of the water level will lead to the float switch blocking the control circuit once again and the safety relays will release. Repeat this operation at least one time.

Switch off the feed voltage and fit the fuses of the elements again. Close the door and reconnect the feed voltage.

1.3 Technical description

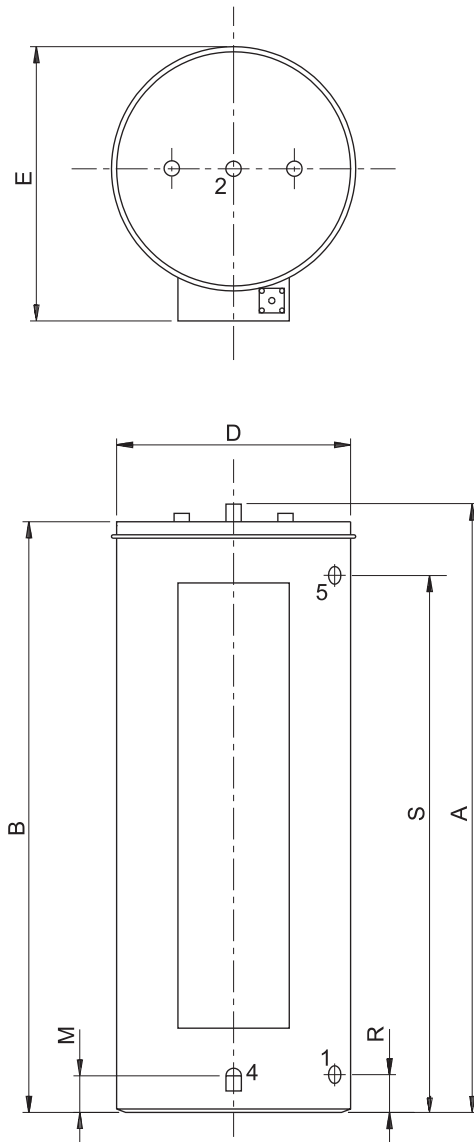

Fig. 3 - Measurements

Measurement Description		52	80	120
A	Height hot water connection	1460	1580	1600
B	Height of upper side of device	1420	1540	1570
D	Diameter of boiler	560	640	750
E	Depth	690	790	910
M	Height of drain valve	125	125	125
R	Height cold water supply	125	125	125
S	Height T&P connection	1230	1335	1380
1	Cold water connection	1¼"-14NPT	1¼"-14NPT	1¼"-14NPT
2	Hot water connection	1¼"-14NPT	1¼"-14NPT	1¼"-14NPT
3	T&P connection	¾"-14NPT	¾"-14NPT	¾"-14NPT
4	Drain plug connection	¾"-14NPT	¾"-14NPT	¾"-14NPT

All measurements are in mm (rounded up to 5mm).

1.4 Technical Data

Type	DRE 52-9	DRE 52-18	DRE 52-36
Tank capacity litres	200	200	200
Number of elements -	3	3	6
Power 380V-3F kW	7.6	15.2	30.3
Power 400V-3F kW	8.4	16.8	33.6
Power 414V-3F kW	9.0	18.0	36.0
Heating time up to 60□* (400/414V) min	83/78	42/39	21/19
Heating time up to 40□* (400/414V) min	50/47	25/23	12/12
Tap capacity 1st hour 60°C** (400/414V) litres	329/339	467/486	741/781
Tap capacity continuous 60°C** (400/414V) litres/hour	145/155	289/310	578/619
Tap capacity 1st hour 40°C** litres	549/565	778/810	1235/1300
Tap capacity continuous 40°C litres/hour	241/258	482/516	963/1032
Weight kg	73	73	73

Type	DRE 80-9	DRE 80-18	DRE 80-36	DRE 80-54
Tank capacity litres	300	300	300	300
Number of elements -	3	3	6	9
Power 380V-3F kW	7.6	15.2	30.3	45.5
Power 400V-3F kW	8.4	16.8	33.6	50.4
Power 414V-3F kW	9.0	18.0	36.0	54.0
Heating time up to 60□* (400/414V) min	125/116	62/58	31/29	21/19
Heating time up to 40□* (400/414V) min	75/70	37/35	19/17	12/12
Tap capacity 1st hour 60°C** (400/414V) litres	425/435	563/582	837/876	1112/1170
Tap capacity continuous 60°C** (400/414V) litres/hour	145/155	289/310	578/619	867/929
Tap capacity 1st hour 40°C** litres	709/725	938/970	1395/1460	1853/1951
Tap capacity continuous 40°C litres/hour	241/258	482/516	963/1032	1445/1548
Weight kg	110	110	110	110

Type	DRE 120-9	DRE 120-18	DRE 120-36	DRE 120-54
Tank capacity litres	450	450	450	450
Number of elements -	3	3	6	9
Power 380V-3F kW	7.6	15.2	30.3	45.5
Power 400V-3F kW	8.4	16.8	33.6	50.4
Power 414V-3F kW	9.0	18.0	36.0	54.0
Heating time up to 60°C* (400/414V) min	187/174	93/87	47/44	31/29
Heating time up to 40°C* (400/414V) min	112/105	56/52	28/26	19/17
Tap capacity 1st hour 60°C** (400/414V) litres	569/579	707/726	981/1020	1256/1314
Tap capacity continuous 60°C** (400/414V) litres/ hour	145/155	289/310	578/619	867/929
Tap capacity 1st hour 40°C** litres	949/965	1178/1210	1635/1700	2093/2191
Tap capacity continuous 40°C litres/hour	241/258	482/516	963/1032	1445/1548
Weight kg	160	160	160	160

* From 10°C cold water

** After heating time up to 60°C from 10°C and assuming a tap efficiency of 80%.

2. FOR THE INSTALLER

2.1 Installation procedures

The device may only be placed in a space if this meets the valid national and local regulations. This space must be frost free or protected against frost.

The device may not be installed in damp or wet areas. The insulation classification of the device is: IP X1

2.1.1 General Installation

The installation shall be carried out by a recognised installation engineer in accordance with the generally and locally applicable regulations for electrical and water companies.

2.1.2 Water Connections

The maximum permissible operating pressure of the device is 8 bar (= 800 kPa).

On the cold water side the device must have a shut off valve and approved inlet combination. The inlet combination must be fitted as closely as possible on the device in accordance with the regulations. The inlet combination must be allowed to work regularly with the aim of avoiding a blockage as a consequence of scale. The drainage pipe of the inlet combination must be fitted in such a way that it constantly slopes upwards. A stop valve or non-return valve must never be fitted between the inlet combination and the device.

During heating of the device, expansion water (as a result of the temperature increase) will drip into the drainage via the

overflow of the inlet combination. This is a normal occurrence. The dripping must never be obstructed and/or blocked. The drain must remain free at all times with regard to the surroundings.

The device must be provided with a temperature and pressure protection mechanism (T&P valve). This is supplied with the device. The overflow of the T&P valve must be connected onto the drain.

When there is a water pipe pressure greater than 8 bar (= 800 kPa) an approved reduction device must also be fitted.. When replacing an old device with a new one the inlet combination must also be renewed.

2.1.3 Electrical Connection

The electrical connection may only be made by a recognised installation engineer in accordance with the valid regulations of the energy company. This device must be provided with an all pole mains switch with a contact separation of at least 3 mm if a fixed connection is used.

Warning: The device must be earthed.

2.1.4 Electrical Diagrams

The electrical circuit diagrams of the various versions are given on the next pages. The regulating and safety sections are the same for all versions. In principle the only difference is the number of elements. An overview is given in the table below.

Diagram A	Diagram B	Diagram C
Electrical diagram for 3 phase connection with 3 elements	Electrical diagram for 3 phase connection with 6 elements	Electrical diagram for 3 phase connection with nine elements
Area of application: DRE 52-9, DRE 52-18 DRE 52-36 DRE 80-54	Area of application: DRE 80-9, DRE 80-18 DRE 80-36 DRE 120-54	Area of application: DRE 120-9 DRE 120-18 DRE 120-36
Feed: 380-415 V AC 3F 50-60 Hz	Feed: 380-415 V AC 3F 50-60 Hz	Feed: 380-415 V AC 3F 50-60 Hz

**Electrical diagram –
3 phases – 3 elements**

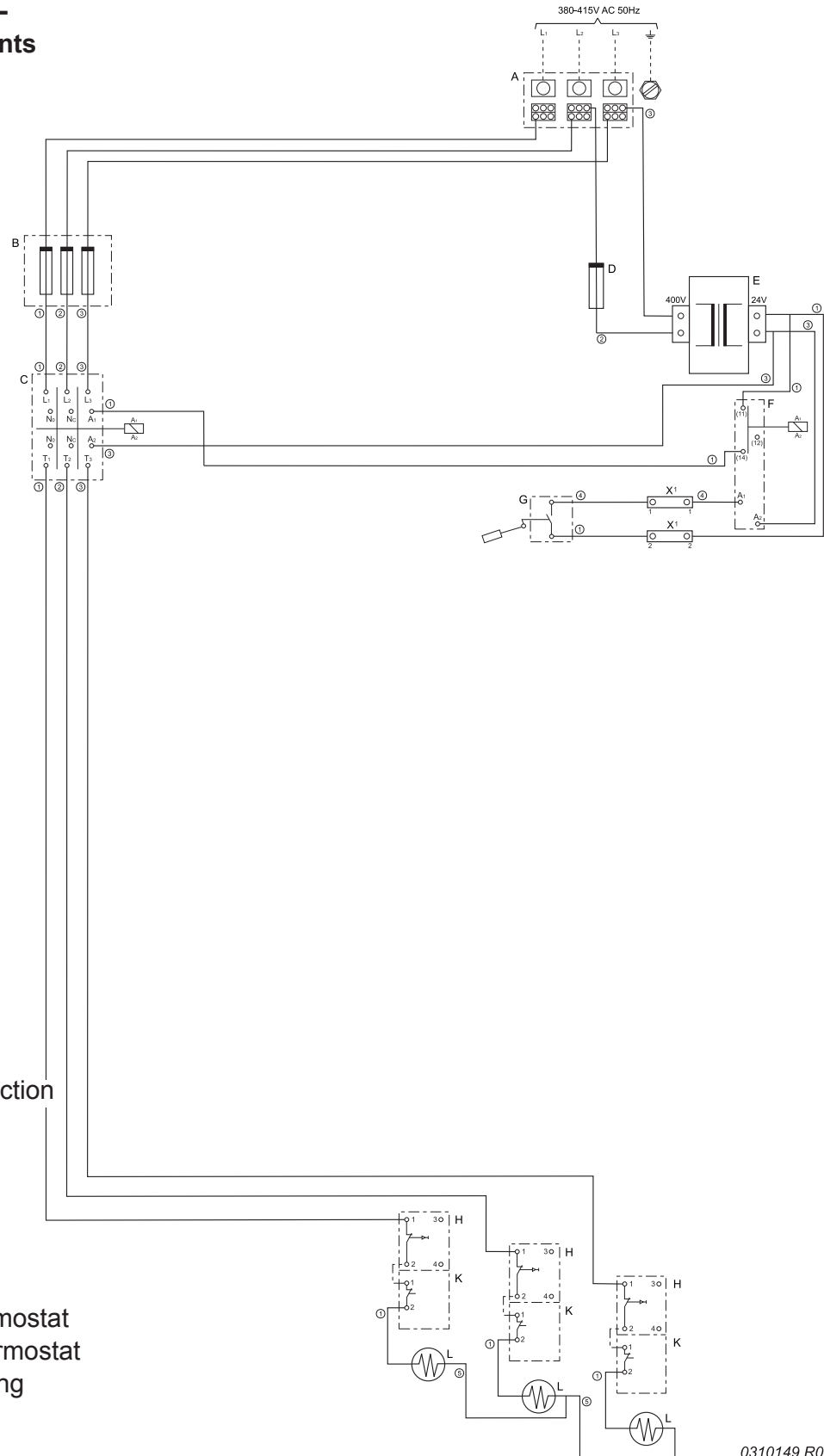

- A = Network connection
- B = Fuses
- C = Relay
- D = Fuse
- E = Transformer
- F = Safety relay
- G = Float switch
- H = Maximum thermostat
- K = Regulation thermostat
- L = Electrical heating element
- X1 = Terminal block

- 1 = Black / Zwart / Schartz / Noir
- 2 = Red / Rood / Rot / Rouge
- 3 = Blue / Blauw / Blau / Bleu
- 4 = Brown / Bruin / Braun / Brun
- 5 = Yellow / Geel / Gelb / Jaune

0310149 R0

Diagram A: Electrical diagram – 3 elements

**Electrical diagram –
3 phases – 6 elements**

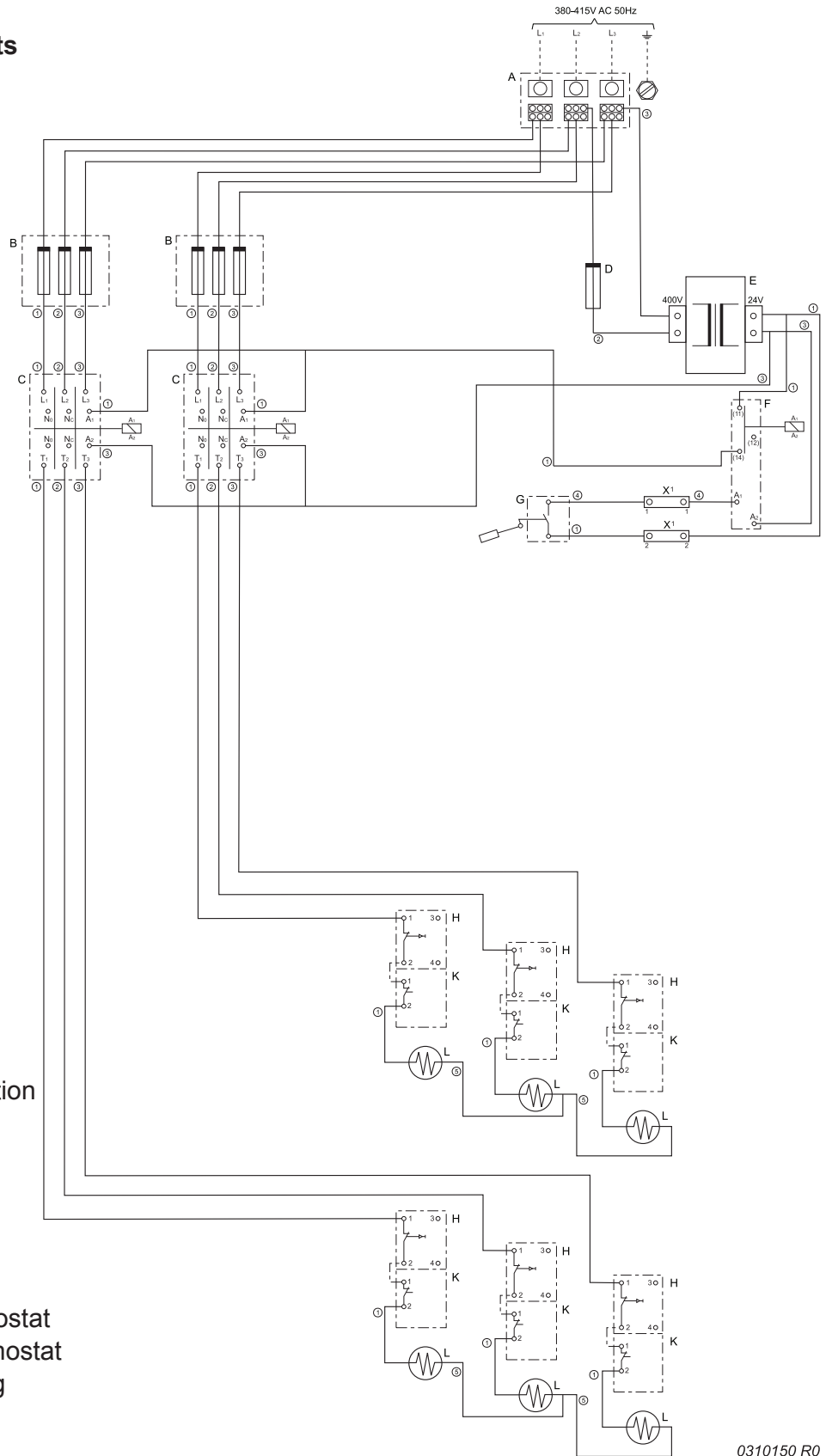

- A = Network connection
- B = Fuses
- C = Relay
- D = Fuse
- E = Transformer
- F = Safety relay
- G = Float switch
- H = Maximum thermostat
- K = Regulation thermostat
- L = Electrical heating element
- X1 = Terminal block

- 1 = Black / Zwart / Schartz / Noir
- 2 = Red / Rood / Rot / Rouge
- 3 = Blue / Blauw / Blau / Bleu
- 4 = Brown / Bruin / Braun / Brun
- 5 = Yellow / Geel / Gelb / Jaune

Diagram B Electrical diagram – 6 elements

0310150 R0

**Electrical diagram –
3 phases – 9 elements**

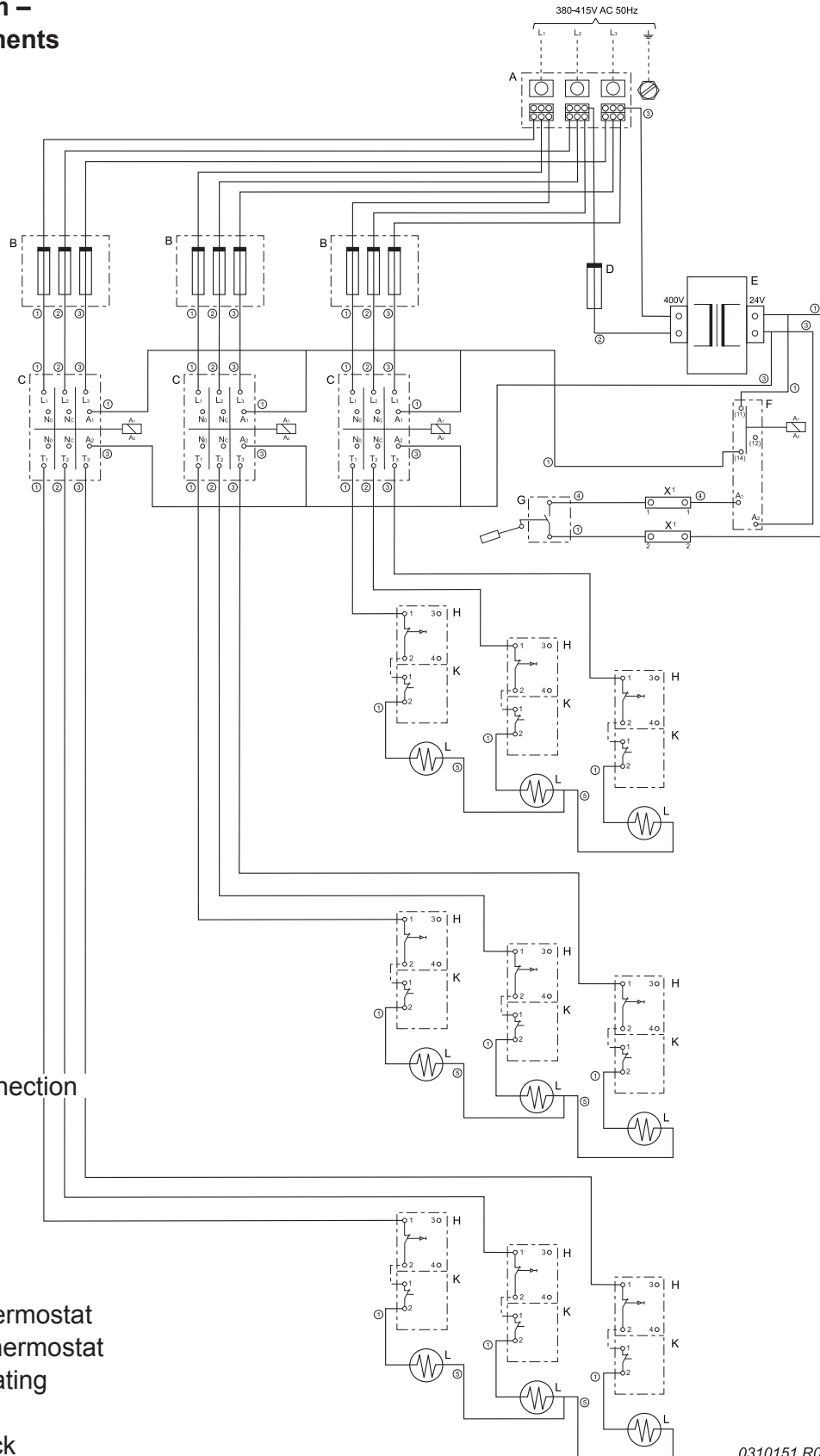

- A = Network connection
- B = Fuses
- C = Relay
- D = Fuse
- E = Transformer
- F = Safety relay
- G = Float switch
- H = Maximum thermostat
- K = Regulation thermostat
- L = Electrical heating element
- X1 = Terminal block

- 1 = Black / Zwart / Schartz / Noir
- 2 = Red / Rood / Rot / Rouge
- 3 = Blue / Blauw / Blau / Bleu
- 4 = Brown / Bruin / Braun / Brun
- 5 = Yellow / Geel / Gelb / Jaune

DIAGRAM C: Electrical diagram – 9 elements

0310151 R0

2.2 Putting into operation

2.2.1 Filling the Device

1. Fit the drain valve and check whether it is closed.
2. Open cold water valve to the boiler and open all valves at hot water drainage points for bleeding. The device is filled as soon as cold water flows at all drainage points.
3. Reclose all valves at hot water drainage points.

2.2.2 Putting Into Operation

The device must NEVER be put into operation with a closed cold water feed.

1. Check whether the device is filled with water and whether all electrical connections to the device are also actually properly connected.
2. Check whether the cold water inlet is open.
3. Check whether the device is free of voltage. Open the door and remove styrofoam cover located beneath it. Now the regulating thermostats are accessible. The regulating thermostats can now be set to the desired temperature by turning the selection knob with a screwdriver.
4. Set the desired temperature on the regulating thermostat (see table). When leaving the factory the temperature is set at 60°C.

Temperature in °F	Temperature in °C
120	49
130	54
140	60
150	66
160	71
170	77
180	82

5. Refit the insulation and close the door.
6. In the case of a fixed connection turn on the mains switch or in other cases place the connector in the stop contact. The device is now switched on and it will continue to work automatically.

2.2.3 Putting out of Operation

1. For short periods: take the connector out of the stop contact or where there is a fixed connection switch off the mains switch.
2. In addition to the operations in point 1, for longer periods it is recommended to shut off the water feed pipe in connection with the danger of frost and once the device has cooled down, to drain off the water by connecting a drainage hose to the drainage valve and opening it. Also open the closest hot water drainage point for ventilating the tank. Take care that the feed pipe and inlet combination cannot freeze. Drain the feed pipe as necessary and check whether all other pipes are empty.

2.2.4 Temperature Regulation

The device is continuously under water pipe pressure (maximum 8 bar (=800 kPa)). Cold water may be fed if hot water is being consumed. The regulating thermostat switches the feed automatically. That means that if the thermostat measures a temperature lower than the set temperature, then it closes the electrical circuit so that an electrical current is conducted through the heating element. As soon as the desired temperature is reached the thermostat breaks the contact once again. When there are high water temperatures, scaling in the device occurs. Therefore it is recommended to allow the temperature setting to stay at 60°C so that less scale is formed. A maximum thermostat is installed above each regulating thermostat which shuts off the current feed to the element permanently (locking) at a water temperature of 93°C. In order to put the element back into operation the reset button of the maximum thermostat must be pressed in. If the temperature climbs above 98°C the temperature and pressure valve fitted open for safety reasons.

2.3 Maintenance

The boiler must be tested and cleaned by a recognised installation engineer at least once per year so that good operation can be guaranteed. During maintenance the device must never be under voltage.

2.3.1 Sacrificial anode

The life of the anodes is determined by the quality and the quantity of water flowing through the device. It is thus recommended that the anodes are checked every year.

1. Close the stop valve in the cold water feed pipe.
2. Open up the nearest hot-water tap so that the water pressure in the boiler and pipeline drops.
3. Loosen the anode using a correct spanner.
4. Check the anode and replace if this is tarnished above 60%.
5. Replace the anode in a water-tight way.

If it is necessary to replace the anode, it must be replaced with one of the same type. The type of anode can be established via the device type and the complete serial number.

2.3.2 Descaling

Scaling depends on the water condition and the water demand. Besides, more scale deposit will be formed in the device at high temperatures than at lower temperatures. A temperature setting of 60°C is recommended to ensure low scale deposit. Descale using the appropriate agents. A descaling instruction is available for detailed information.

2.4 Steps When There is a Fault

Warning:

Always ensure that the device is completely free of voltage before the door is opened!

In normal operation the safety relays are in a taut condition. When the feed voltage is switched off these drop. This is clearly audible. If the switching on and off of the relay is not audible, then check whether feed voltage is present and the fuses of the feed are in order. If this is in order then check (with a voltage free device!) the following (see also 1.2 Regulation and Protection):

1. Check the fuse of the transformer in the current circuit
2. Check whether the water level in the device is sufficiently high (boil dry protection).
4. Check whether the fuses of the heating elements are in order.
5. Check whether the maximum thermostats of the elements have connected by pressing in the reset buttons of all thermostats.
6. Close the door and reconnect the feed voltage. If the safety relays do not connect or if the device does not function properly then engage a repair service.

Explanation

All devices are made with a number of maximum thermostats which break the circuit when the water temperature is too high (93°C). These maximum thermostats can only be reset again once the temperature has dropped 20°C. Then the regulating thermostat must be examined: if this is set at too high a temperature, the thermostat must be set lower. If it is not set to a high temperature it is probably defective and in this case it must be replaced. Check the fuses as well and replace them if necessary. The fuses can be ordered through A.O. Smith.

2.4.1 Water Temperature Not Good

1. Check the settings of the regulating thermostat.
2. Check for leaks or open valves.
3. Check the hot water temperature right by the pipe leading out from the device in order to be sure that a too low water temperature is not caused by the mixing of cold water into the pipe system.
4. Check if the wiring has been properly connected.
5. Check whether the voltage between the three phases is 380-415 V.
6. Check whether the need for hot water is greater than initially calculated.

2.4.2 Presumed Water Leakage

1. Check whether the drain valve is fully closed.
2. Check whether all water connections are water tight.

2.4.3 Fault Table

Fault	Cause	Solution
Insufficient or no hot water	Temperature set too low	Set regulating thermostats higher.
	Maximum thermostats break the circuit.	Press in reset button.
	Connector is not seated in stop contact, mains switch is off or fuses are broken.	Check the relevant parts.
	Cause cannot be ascertained.	Switch off device and ask for help from technical support
Leakage	Insufficient sealing of the water connections.	Tighten the screw thread connections.
	Leakages from other water devices or pipes nearby.	Trace the cause

2.5 Spare Parts

Prior to ordering spare parts it is important to note the device type and the full serial number of the device. This information is given on the plate which is affixed to the outside of the door. Data for spare parts can be established by using this information.

3. FOR THE USER

3.1 Instructions for Use

Warnings

The installation and commissioning shall be done by a recognised installer.

Always make the device free of voltage before opening the door. Have maintenance and fault rectification carried out by authorised personnel. Never work on the device while feed voltage is still present.

The device may not be operated by people (including children) with limited psychological and/or mental abilities, lack of experience and knowledge unless they have received agreement or instruction from a person who is held responsible for their safety.

From the point of view of safety it must be ensured that children do not play with the device.

3.1.1 Filling the Device

Method of working:

1. Check whether the drain valve is closed.
2. Open cold water valve to the boiler and open all valves at hot water drainage points for bleeding. The device is filled as soon as cold water flows at all drainage points.
3. Reclose all valves at hot water drainage points.

3.1.2 Putting into operation

Method of working:

1. Check whether the device is filled with water.
2. Switch the mains switch on for a fixed connection or place the connector in the stop contact.

3.1.3 Use

The device is under water pipe pressure (maximum 8 bar (=800 kPa)). As much cold water is fed as hot water consumed. The regulating thermostat switches the electrical feed automatically. This means that if the temperature rises above the desired temperature, the circuit is closed and heat is fed to the water. The circuit is broken once again when the desired temperature is reached.

Changing the set temperature is an operation which must be carried out by a recognised installer. For this purpose the device must be made completely voltage free before the access door to the regulating thermostats may be opened.

Temperature in °F	Temperature in °C
120	49
130	54
140	60
150	66
160	71
170	77
180	82

In connection with limiting scaling it is recommended to set the temperature at 60°C. A maximum thermostat is also installed which interrupts the circuit fully at a water temperature of 93°C. This thermostat can be reset again once the temperature of the water has dropped by 20°C. If the maximum thermostat intervenes again the regulating thermostat must be set to a lower temperature.

3.1.4 Putting out of operation

Method of working:

1. For short periods: take the connector out of the stop contact or where there is a fixed connection switch off the mains switch.
2. In addition to the operations in point 1, for longer periods it is recommended to shut off the water feed pipe in connection with the danger of frost and once the device has cooled down, to drain off the water by connecting a drainage hose to the drainage valve and opening it. Also open the closest hot water drainage point for ventilating the tank. Take care that the feed pipe and inlet combination cannot freeze. Drain the feed pipe as necessary and check whether all other pipes are empty.

3.2 Maintenance

The inlet combination must be allowed to work regularly (testing with the test button) with the aim of avoiding a blockage as a consequence of scale. The water has to flow out in a forceful jet. Check whether the discharge pipe is open. We recommend a service agreement with an installer on an annual basis.

3.3 Faults

In the case of faults we advise you to switch off the device by means of the mains switch and to ask a recognised installer of technical support for help.

4. WARRANTY

4.1 General Warranty

If, within one year from the original installation date, after investigation and exclusive evaluation by A.O. Smith, a boiler delivered by A.O. Smith turns out to have a part, with the exception of the tank, that is not properly functioning as a result of manufacturing or material faults, A.O. Smith will replace or repair this part.

4.2 Tank Warranty

If, within 3 years of the original installation date, after investigation and exclusive evaluation by A.O. Smith, a boiler delivered by A.O. Smith turns out to have a steel glass-lined tank that is leaking as a result of rust or corrosion from the water side, A.O. Smith will replace the whole boiler by a completely new one of similar size and quality. The replacement boiler will have a warranty that will be valid for the remaining period of the warranty for the original boiler delivered.

Notwithstanding the provisions in Article 2, the warranty term will be reduced to one year after the original installation date if unfiltered or softened water is flowing through the boiler or left in it.

4.3 Conditions of installation and use

The warranty referred to in Articles 1 and 2 only applies if the following conditions are met:

- a) that the boiler is installed according to the installation instructions of A.O. Smith for the specific model, as well as according to the local and national installation and building regulations, instructions and rules;
- b) that the boiler will remain installed in the original installation position;

- c) that only drinking water is used, which is allowed to circulate freely at all times (a separately installed heat exchanger is requisite for the heating of saline or corrosive water);
- d) that the tank has been defurred to remove harmful scale deposits by means of periodic maintenance;
- e) that the boiler-water temperatures do not exceed the maximum settings of the thermostats that are part of the boiler;
- f) that the water pressure and/or heat load do not exceed the maximum values indicated on the boiler's identification plate;
- g) that the boiler has not been installed in a corrosive atmosphere or environment;
- h) that the boiler has been provided with an inlet combination, approved by an authorised body, of sufficient capacity, not greater than the operating pressure indicated on the boiler, and, if applicable, with a temperature and pressure relief valve, also approved by an authorised body, which has been mounted according to the installation instructions of A.O. Smith that apply to the specific boiler model, as well as according to the local and national instructions, regulations and rules;
- i) that the anodes are replaced and renewed if and when they have 60 % or more wear.

4.4 Exclusions

The warranty referred to in Articles 1 and 2 does not apply:

- a) if the boiler has been damaged by an external cause;
- b) in case of abuse, neglect (including freezing), modification, incorrect and/or deviating use of the boiler and if attempts have been made to repair leaks;
- c) if contamination or other impurities were allowed to flow into the tank.
- d) if the conductivity of the water is less than 150 microSiemens and/or the hardness of the water is less than 6°DH;
- e) if unfiltered, recirculated water flows through or is stored in the boiler;
- f) if the owner has attempted to repair a defective boiler himself;

4.5 Extent of the warranty

A.O. Smith's commitments pursuant to the warranty provided are confined to the delivery free of charge of the boiler to be replaced or any parts thereof ex the Veldhoven warehouse. Any costs involved with transport, labour, installation or any other capacity connected to the replacement cannot be charged to A.O. Smith.

4.6 Claims

A claim based on the warranty provided shall be deposited with the dealer from whom the boiler was purchased or any other dealer who sells products manufactured by A.O. Smith. The examination of the boiler as referred to in the Articles 1 and 2 will take place in an A.O. Smith laboratory.

4.7 No obligations for A.O. Smith other than those specified here.

In relation to its boilers or else the boilers (or parts or components thereof) supplied for replacement, no warranty or guarantee is given by A.O. Smith other than the warranty given here. A.O. Smith will not be held liable for any damage to property or persons under the warranty given or in any other way caused by a boiler it has supplied (parts or components or the steel glass lined tank) (for replacement).

DRE 52
DRE 80
DRE 120

