

ITE

Indirect calorifier-solar

ITE - 400/500/600/750/1000



Indirect water heater (calorifier) for solar applications • Single-wall spiral heat exchanger • PermaGlas Ultra Coat second-generation glass coating technology prevents corrosion • ITE 400-1000: Insulated ring base • Insulated access cover for comprehensive waterside maintenance • Replaceable magnesium anode • Options: Flexible magnesium anode for installation in confined areas • Powered anode for reduced maintenance requirements • Temperature and pressure valve with stainless steel spring set to 95°C and a maximum water pressure of (7 bar) 700 kPa • Analogue temperature gauge (0-120°C) • Electric element heat packs (3 - 36 kW) • Optional ancillaries: unvented kits • Destratification pump kit

Technical specifications

		ITE 400	ITE 500	ITE 600	ITE 750	ITE 1000
Technical data						
Output coil	kW	52	68	72	80	87
Surface area coil	m ²	2.45	3.11	3.45	3.72	4.82
Water capacity coil	l	14.8	18.8	29.3	31.6	40.9
Flow rate coil (80-60°C)	l/h	2236	2924	3096	3440	3741
Pressure drop coil	mbar	244	489	104	128	259
Maximum working pressure tank	kPa (bar)	1000 (10)				
Maximum working pressure coil	kPa (bar)	1600 (16)				
Maximum operating temperature tank	°C	95				
Maximum operating temperature coil	°C	110				
Standby loss	kWh/24h	1.60	1.88	1.85	2.03	2.19
Draw-off capacity						
Tcold = 10°C/Tset = 80°C						
Storage capacity	l	389	478	652	734	1024
30 min. ΔT=44°C	l	952	1206	1463	1638	2068
60 min. ΔT=44°C	l	1461	1871	2167	2420	2919
90 min. ΔT=44°C	l	1969	2536	2870	3201	3769
120 min. ΔT=44°C	l	2477	3200	3574	3983	4619
Continu ΔT=44°C	l/h	1016	1329	1407	1564	1700
Opwarmtijd ΔT=44°C	min.	23	22	28	28	36
30 min. ΔT=50°C	l	838	1062	1288	1441	1820
60 min. ΔT=50°C	l	1285	1646	1907	2129	2568
90 min. ΔT=50°C	l	1733	2231	2526	2817	3317
120 min. ΔT=50°C	l	2180	2816	3145	3505	4065
Continu ΔT=50°C	l/h	894	1170	1238	1376	1496
Opwarmtijd ΔT=50°C	min.	26	25	32	32	41
30 min. ΔT=55°C	l	762	965	1170	1310	1655
60 min. ΔT=55°C	l	1169	1497	1733	1936	2335
90 min. ΔT=55°C	l	1575	2028	2296	2561	3015
120 min. ΔT=55°C	l	1982	2560	2859	3187	3695
Continuous ΔT=55°C	l/h	813	1063	1126	1251	1360
Heating-up time ΔT=55°C	min.	24	27	35	35	45
Shipping data						
Weight empty	kg	131	179	229	237	314
Maximum weight	kg	520	657	881	971	1338
Weight incl. packaging	kg	153	201	251	260	348
Width packaging	mm	780	780	870	870	1010
Height packaging	mm	1850	2150	1930	2150	2100
Depth packaging	mm	780	780	870	870	1010

Dimensions

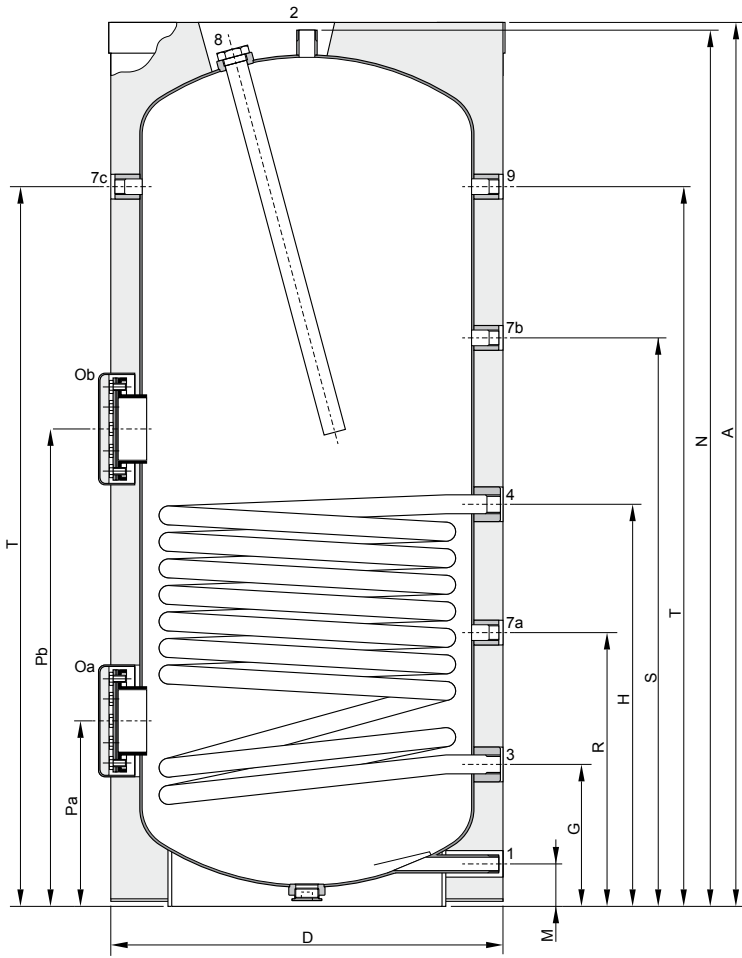

	ITE 400	ITE 500	ITE 600	ITE 750	ITE 1000
A	1705	2040	1835	2030	2000
D	720	720	910	910	1060
G	255	255	304	305	345
H	771	915	906	967	947
M	70	70	85	85	95
N	1652	1990	1797	1992	1962
Oa/Ob	115	115	180	180	180
Pa	330	330	412	413	447
Pb	897	1029	1062	1113	1087
R	500	500	649	650	700
S	1096	1288	1236	1297	1397
T	1362	1700	1476	1627	1602

1	Cold water	R2 (ITE 600-1000 R2½)
2	Hot water	R2 (ITE 600-1000 R2½)
3	Inlet coil	Rp1 (ITE 750-1000 Rp1½)
4	Outlet coil	Rp1 (ITE 750-1000 Rp1½)
7	Connection	Rp¾
8	Anode connection	Rp1¼
9	Connection (female)	1"-1½ NPT

Dimensions in mm.
Dimensions for ITE 1500-3000 available upon request.



Installation diagrams

Unvented

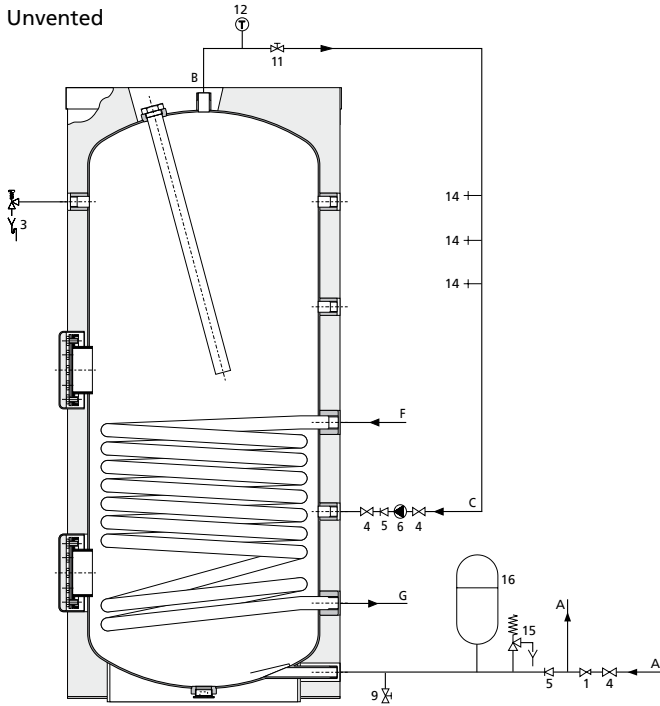

- 1 Pressure reducing valve
 - 3 T&P valve
 - 4 Stop valve
 - 5 Non-return valve
 - 6 Circulation pump
 - 9 Drain valve
 - 11 Service valve
 - 12 Temperature meter
 - 14 Hot water tap
 - 15 Expansion valve
 - 16 Expansion vessel
 - 17 Three way valve
 - 18 Water cistern
 - 19 Float valve
- A Cold water supply
 B Hot water outlet
 C Return circulation
 F Primary flow
 G Primary return
 E Over flow pipe
 H Expansion pipe

A.O. Smith unvented system kits utilise combination valves.

Vented

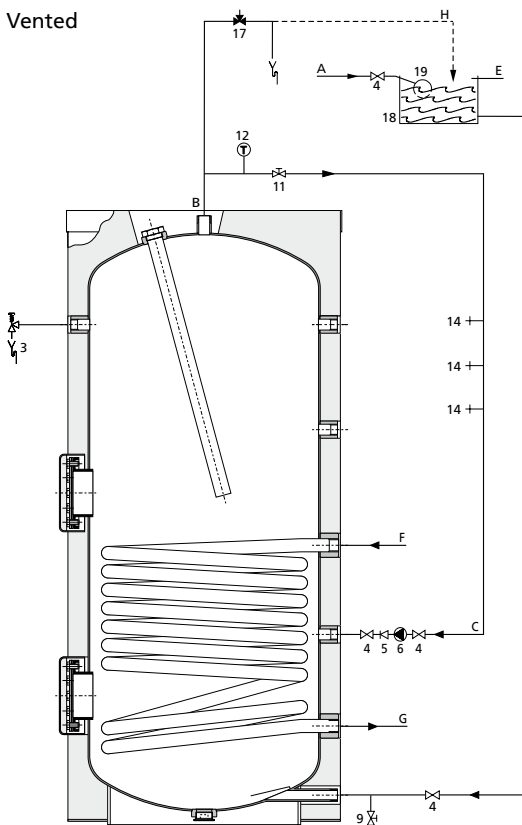

Further installation and connection details can be found in the Installation & Commissioning Manual.