

# COF

## Commercial gas/oil forced draft water heater

COF - 199/245/315/385/455/700



Wide range of water heaters designed for use with pressure jet oil and gas burners • Compatible with other forced draft plant • Riello gas and oil burners supplied as standard. Other burners that meet the combustion specifications can be used if required • Universal burner mounting plate • Simple and easy accessible controls • Waterway access cover for comprehensive waterside tank maintenance • Replaceable magnesium anodes • Voltage-free contact for general fault indication • Optional ancillaries: Unvented kits • Destratification pump kit • Powered anodes

# Technical specifications

		COF 199	COF 245	COF 315	COF 385	COF 455	COF 700
<b>Gas data gas 2H (G20)</b>							
Input*	kW	66.6	83.8	99.9	127.7	149.9	194.3
Output	kW	50.4	63.0	75.6	96.9	113.4	147.0
Inlet pressure	mbar	20	20	20	20	20	20
Gas consumption**	m <sup>3</sup> /h	6.3	7.9	9.5	12.2	14.3	18.5
Burner model	-	BS 2	BS 2	BS 3	BS 3	BS 3	BS 3
Burner type	-	912 T1	912 T1	913 T1	913 T1	913 T1	913 T1
<b>Gas data butane (G30)</b>							
Input*	kW	65.0	81.3	97.5	124.6	146.3	189.7
Output	kW	50.4	63.0	75.6	96.6	113.4	147.0
Inlet pressure	mbar	30	30	30	30	30	30
Gas consumption**	kg/h	4.7	5.9	7.1	9.1	10.6	13.8
Burner model	-	BS 2	BS 2	BS 3	BS 3	BS 3	BS 3
Burner type	-	912 T1	912 T1	913 T1	913 T1	913 T1	913 T1
<b>Gas data propane (G31)</b>							
Input*	kW	65.2	81.5	97.8	125.0	146.7	190.2
Output	kW	50.4	63.0	75.6	96.6	113.4	147.0
Inlet pressure	mbar	37	37	37	37	37	37
Gas consumption**	kg/h	4.7	5.8	7.0	8.9	10.5	13.6
Burner model	-	BS 2	BS 2	BS 3	BS 3	BS 3	BS 3
Burner type	-	912 T1	912 T1	913 T1	913 T1	913 T1	913 T1
<b>Oil data (HBO I)</b>							
Input* (lower value)	kW	62.8	75.4	87.9	113.0	138.0	201.0
Output	kW	52.8	63.3	73.8	94.9	115.9	168.8
Pump pressure	kPa (bar)			1200 (12)			
Oil flow rate***	kg/h	5.3	6.3	7.4	9.5	11.6	16.9
Burner model	-	RG 2	RG 2	RG 3	RG 3	RG 3	RG 45
Burner type	-	377 T1	377 T1	393 T1	393 T1	393 T1	396 T1
<b>General</b>							
Efficiency (gross)	%	76	76	76	76	76	76
Weight empty	kg	230	230	240	265	265	305
Maximum weight (incl. burner)	kg	582	582	588	577	577	594
Storage capacity	l	322	322	318	282	282	259
Max. temperature setting	°C	80	80	80	80	80	80
Maximum working pressure	kPa (bar)			800 (8)			
<b>Draw-off capacity</b>							
T <sub>cold</sub> = 10°C / T <sub>set</sub> = T <sub>max</sub>							
30 min. ΔT=44°C	l	853	964	1070	1209	1356	1623
60 min. ΔT=44°C	l	1346	1580	1808	2153	2465	3059
90 min. ΔT=44°C	l	1838	2195	2547	3097	3573	4496
120 min. ΔT=44°C	l	2331	2811	3286	4041	4681	5932
Continuous ΔT=44°C	l/h	985	1231	1478	1888	2216	2873
Heating-up time ΔT=44°C	min.	20	16	13	9	8	5
30 min. ΔT=50°C	l	751	848	941	1064	1194	1428
60 min. ΔT=50°C	l	1184	1390	1591	1894	2169	2692
90 min. ΔT=50°C	l	1618	1932	2242	2725	3144	3956
120 min. ΔT=50°C	l	2051	2474	2892	3556	4119	5221
Continuous ΔT=50°C	l/h	867	1084	1300	1662	1951	2528
Heating-up time ΔT=50°C	min.	22	18	15	10	9	6
30 min. ΔT=55°C	l	682	771	856	967	1085	1298
60 min. ΔT=55°C	l	1077	1264	1447	1722	1972	2447
90 min. ΔT=55°C	l	1471	1756	2038	2477	2858	3597
120 min. ΔT=55°C	l	1865	2249	2629	3233	3745	4746
Continuous ΔT=55°C	l/h	788	985	1182	1510	1773	2299
Heating-up time ΔT=55°C	min.	25	20	16	11	10	7
<b>Electrical data</b>							
Power consumption	W	180	180	385	385	385	390
Power supply	VAC/Hz			230 (-15% +10%) / 50 (± 1 Hz)			
<b>Shipping data</b>							
Weight incl. packaging (incl. burner)	kg	240	240	250	275	275	315
Width packaging	mm	770	770	770	770	770	770
Height packaging (excl. burner)	mm	2150	2150	2150	2150	2150	2280
Depth packaging	mm	970	970	970	970	970	970

\* Gas data on gross value

\*\* Gas consumption at 15°C and 1013.25 mbar

\*\*\* Oil flow rate at 20°C and 1013.25 mbar

# Dimensions

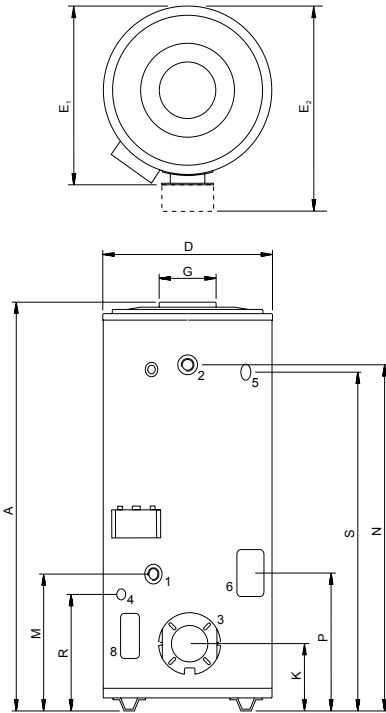

	COF 199	COF 245	COF 315	COF 385	COF 455	COF 700
A	1900	1900	1900	1900	1900	1990
D	705	705	705	705	705	705
E	725	725	725	725	725	725
G	150	200	200	200	200	250*
K	295	295	295	295	295	330
M	685	685	685	640	640	765
N	1700	1700	1720	1650	1650	1770
P	620	620	620	620	620	755
R	540	540	585	605	605	670
S	1700	1700	1700	1630	1630	1750
1	Cold water supply				Rp1 <sup>1</sup> / <sub>2</sub>	
2	Hot water outlet				Rp1 <sup>1</sup> / <sub>2</sub>	
4	Tank drain valve				3/4 - 14 NPT	
5	T & P valve				1 - 11.5 NPT	
6	Cleaning and inspection opening				95x70	
* After installing flue reducer						
Dimensions in mm.						

# Installation diagrams

## Vented

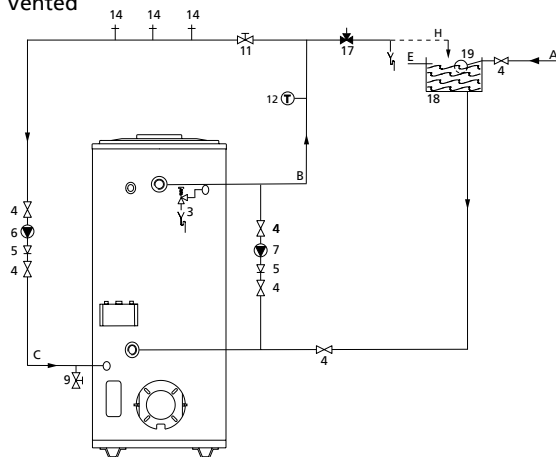

- 1 Pressure reducing valve
- 3 T&P valve
- 4 Stop valve
- 5 Non-return valve
- 6 Circulation pump
- 7 Destratification pump
- 9 Drain valve
- 11 Service valve
- 12 Temperature meter
- 14 Hot water tap
- 15 Expansion valve
- 16 Expansion vessel
- 17 Three way valve
- 18 Water cistern
- 19 Float valve

## Unvented

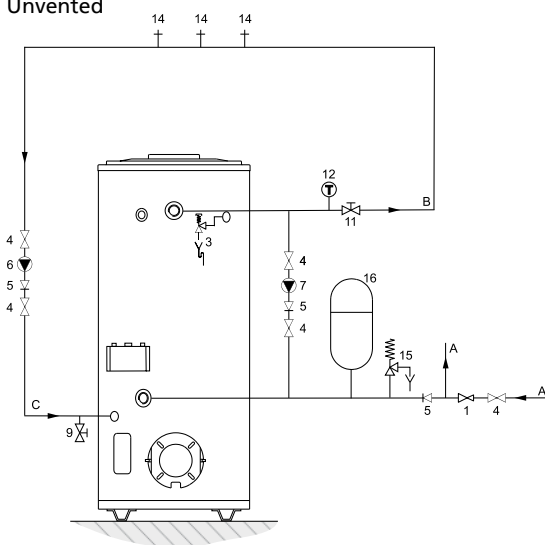

- A Cold water supply
- B Hot water outlet
- C Circulation pipe
- E Overflow pipe
- H Overflow protection

A.O. Smith unvented system kits utilise combination valves.

Further installation and connection details can be found in the Installation & Commissioning Manual.

# Flue system

A COF water heater should be installed according category B23.

Maximum flue length for the COF 199 to 700 is 100 metres.  
Subtract three meters for each bend. When the flue system exceeds 10 metres, a condensation drain should be installed.

Note:

- On the COF 199 & 700 units a flue adaptor ring must be installed.
- For oil-fired units a stainless steel flue system should be utilised.
- Horizontal flue runs must be installed with a fall of at least 5 mm per metre.

## Water heater- and flue gas check

Before the water heater is commissioned, the items below need to be checked and/or adjusted (also see installation manual).

	Gas	Oil
Check	Burner pressure Combustion figures	Top angle nozzle (80°) (brand = Delavan)
Adjust at location	Burner head Air valve Switch point of air proving switch Gas pressure switch (inlet gas control)	Burner head Air valve