

MODELS

**COF 199 G
COF 245 G
COF 315 G
COF 385 G
COF 455 G
COF 700 G**

**INSTALLATION INSTRUCTIONS
AND
USERS MANUAL**

UNITED KINGDOM / IRELAND

WATER HEATERS

FOREWORD

Before attempting to install this water heater please read the installation instructions. Read the users manual before igniting the heater. Failure to follow these instructions meticulously could lead to the risk of an explosion and/or a fire and can cause material and/or physical injuries.

An accredited installer must install the heater and commission it according to the locally valid requirements. The heater may only be installed in an area that meets the required ventilation regulations.

A.O. SMITH CANNOT ACCEPT ANY RESPONSIBILITY FOR GUARANTEE, SERVICE AND/OR PRODUCT LIABILITY IN THE EVENT OF UNAUTHORIZED CHANGES, PRODUCT MODIFICATIONS OR REPAIRS.

1.	GENERAL	
1.1	Description of the heater	4
1.2	Technical safety equipment	4
1.2.1	Control box	4
1.3	Technical description	6
1.3.1	Dimensions	6
1.3.2	Burners	8
1.3.3	Technical data	9
1.3.4	Air-proving switch	11
1.3.5	Gas-pressure switch	12
1.3.6	Setting the burner switch	13
1.3.7	Setting the air valve	14
2.	FOR THE INSTALLER	
2.1	Installation procedure	15
2.1.1	Installation	15
2.1.2	Water connections	15
2.1.2.1	Vented system	16
2.1.2.2	Unvented system	17
2.1.3	Gas connection	19
2.1.4	Flue gas exhaust	19
2.1.5	Burner connection	19
2.1.6	Electrical connection	19
2.2	Commissioning	19
2.2.1	Filling the heater	19
2.2.2	Turning on the burner	19
2.3	Shutting down	19
2.4	Usage/temperature control	19
2.5	Setting the nominal load	20
2.6	Conversion to another gas type	20
2.7	Maintenance	20
2.8	Anode	20
2.9	Descaling	21
2.10	Condensation	21
2.11	Spare parts	21
3.	FOR THE USER	
3.1	Instructions for use	22
3.1.1	Lighting the heater	22
3.1.2	Filling the heater	22
3.1.3	Commissioning	22
3.2	Operation	22
3.3	Shutting down	22
3.4	Maintenance	22
4.	WHAT TO DO IN CASE OF FAILURE	
4.1	General	23
4.2	Fault overview	23
5.	WARRANTY	
5.1	Guarantee in general	24
5.2	Guarantee of the tank	24
5.3	Conditions for installation and use	24
5.4	Exclusions	24
5.5	Range of guard	24
5.6	Claims	24
5.7	No other guarantee or warranty either expressed or implied is made on behalf of A.O. Smith	24
6.	APPENDIX	
6.1	Electrical diagram COF	25

1. GENERAL

1.1 Description of the heater

Construction of the heater is in accordance with the European standards for gas-fired water heaters for sanitary use (EN 89). The heaters therefore comply with the European Guidelines for Gas Heaters and are permitted to carry the CE mark.

They are atmospheric heaters suitable for both gas-fired and oil-fired ventilator burners (heater category B23).

The heaters are suitable for use with a working pressure of up to 8 bar. The cylindrical tank is made from sheet steel containing a number of vertically placed flue tubes. For protection against corrosion, the inside of the tank is glass lined. The tank is also fitted with a number of magnesium anodes for extra protection against corrosion. A thick PU insulating layer between the tank and the steel jacket helps to reduce heat loss. When the heater is completely filled with water, it is under continuous mains water pressure. When hot water is drained from the heater, cold water immediately enters the heater. For effective heat transfer, flue baffles have been included in the flue tubes. Heat from the flue gases is transferred to the water by means of radiation and convection.

1.2 Technical safety equipment

1.2.1 Control box

The temperature control for the water heater is situated in the control box (see figure 1), which is fitted to the heater cover.

The water heater has been fitted with three thermostats:

- a control thermostat,
- a high-limit thermostat
- an overheating cut-out.

The control thermostat is the thermostat by means of which the desired water temperature is set.

The high-limit thermostat acts as a safeguard against excessive water temperatures at the top of the heater, if as a result from a certain draining pattern (frequently draining of small quantities), stratification of the water temperatures in the heater occur. If both the control thermostat and the high-limit thermostat fail the overheating cut-out will automatically shut down the water heater.

The overheating cut-out interrupts the current supply to the burner, as a result of which the gas valves of the gas block will close.

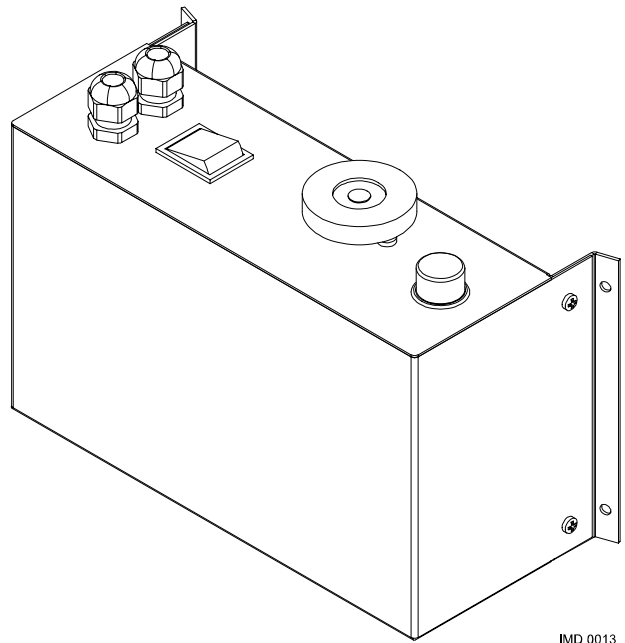

Figure 1: Control box COF

The control thermostat can be set between 40°C and 80°C by means of the temperature control knob.

The high-limit thermostat switches at 84°C, the overheating cut-out at 95°C.

The control thermostat's sensor is located in the lower immersion well in the control box; the sensors of the high-limit thermostat and overheating cut-out are located in the immersion well at the top of the heater.

If the overheating cut-out is activated, it must be manually reset. This is only possible when the temperature at the top of the heater has dropped below 89°C.

The control box is fitted with an 'ON/OFF' switch ('I/O'). In position 'I' the ventilator burner is controlled on the basis of the heat demand from the control thermostat. In position 'O' the heater is switched off.

1.3 Technical description

1.3.1 Dimensions

(See figure 2).

Size	COF 199	COF 245	COF 315	COF 385	COF 455	COF 700
A	1900	1900	1900	1900	1900	2025
B	685	685	685	640	640	765
C	585	585	585	605	605	745
D	705	705	705	705	705	705
E	150*	200	200	200	200	250*
F	1700	1700	1700	1630	1630	1770
G	1720	1720	1720	1650	1650	1785
1	Hot water outlet					
2	Cold water inlet					
3	Drain valve					
4	Burner fixing flange					
5	T & P connection (temperature and pressure valves)					
6	Inspection opening					
7	Cleaning opening					

All dimensions are in millimetres (rounded off to the nearest 5 mm)

* after installing the flue reducer

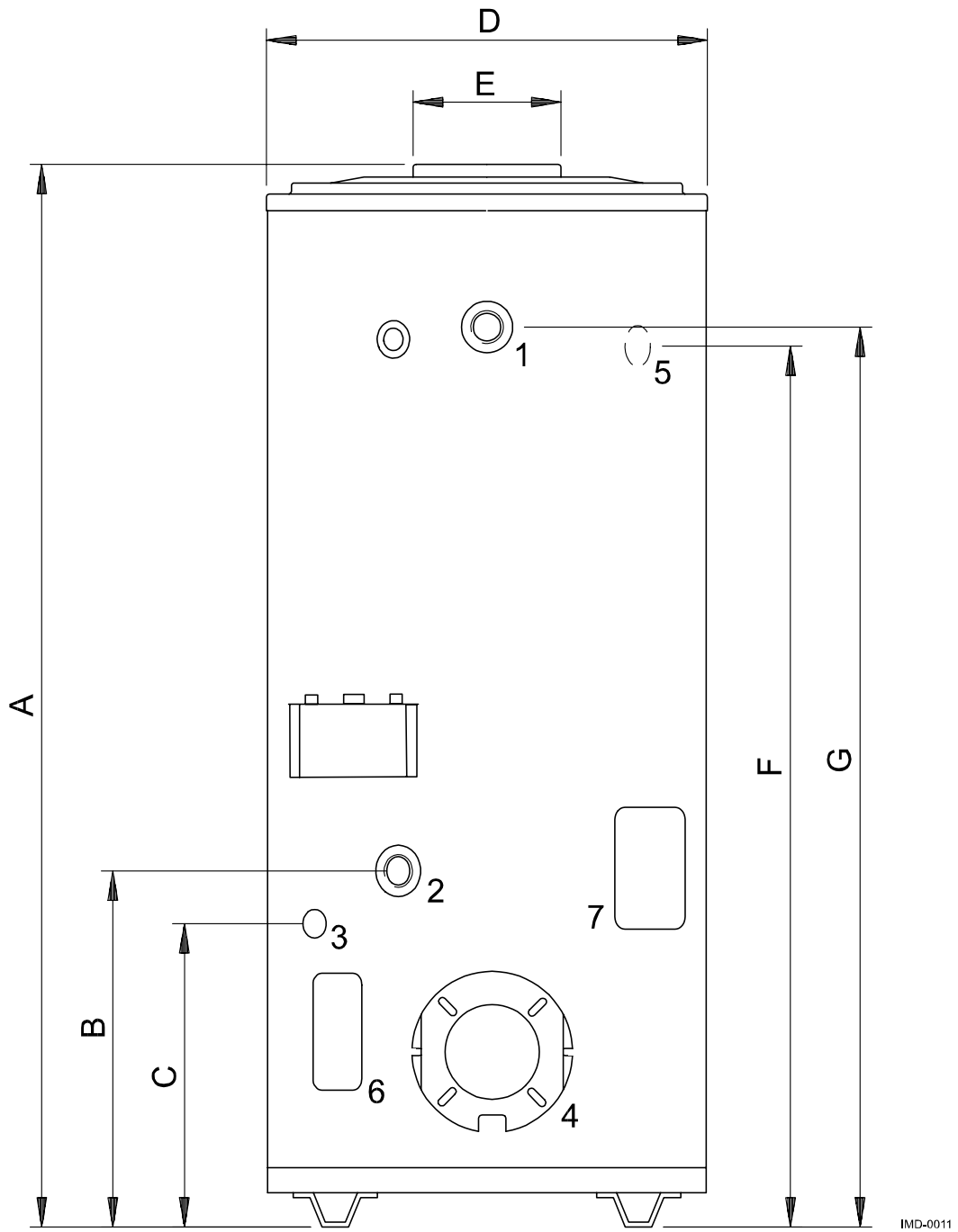

Figure 2: Dimensions

1.3.2 Burners

The water heaters are suitable for both gas-fired and oil-fired burners.

The water heaters have been examined and tested with the following front-mounted burners from Riello:

HEATER	GAS-FIRED BURNER		OIL-FIRED BURNER	
	MODEL	TYPE	MODEL	TYPE
COF 199	BS 2	912 T1	RG 2	377 T1
COF 245	BS 2	912 T1	RG 2	377 T1
COF 315	BS 3	913 T1	RG 3	393 T1
COF 385	BS 3	913 T1	RG 3	393 T1
COF 455	BS 3	913 T1	RG 3	393 T1
COF 700	BS 3	913 T1	RG 4S	396 T1

The burners for the COF 700 heaters must be fitted with a special fire tube in view of the higher temperatures in the heater's combustion chamber. The manufacturer has already fitted the special fire tube to a burner supplied direct with the water heater. Otherwise the special fire tube must be retrofitted. Please consult your supplier on this matter.

The heaters are also suitable for front-mounted burners from other manufacturers, provided that the following conditions are met:

- The front-mounted burners must be EC approved,
- The flame length of the front-mounted burner must be less than the diameter of the heater's combustion chamber. This diameter is 510 mm for all heaters,
- For the COF 455 and COF 700 a starting load of 120 kW at maximum (according to EN 676) must be set. Consult to this end the instruction manual of the front-mounted burner used,
- The air-proving switch must be set in such a way that it cuts out before the CO contents of the flue gas reaches a value of 2000 ppm.
- The maximum burner pressure of the heater amounts to 25 Pa across the entire range. The selected burner must be able to supply at least this pressure.

Before installing and commissioning the selected burner, you must consult the front-mounted burner's instruction manual.

1.3.3 Technical data

The data below only apply to front-mounted burners from Riello

Oil: fuel oil, max. viscosity at 20°C: 6 mm²/s

DESCRIPTION	Unit	COF 199	COF 245	COF 315	COF 385	COF 455	COF 700
NATURAL GAS DATA (G20-20 mbar):							
Burner model	[-]	BS 2	BS 2	BS 3	BS 3	BS 3	BS 3
Burner type	[-]	912 T1	912 T1	913 T1	913 T1	913 T1	913 T1
Nominal load (lower value)	kW	60	75	90	115	135	175
Nominal power	kW	50.4	63	75.6	96.6	113.4	147
Pre-pressure	mbar	20	20	20	20	20	20
Burner pressure	mbar	3.3	5.0	3.0	4.2	4.6	9.1
Gas consumption *	m ³ /h	6.4	7.9	9.5	12.2	14.3	18.5
Heating up time $\Delta T = 45K$	min	20	16	13	9	8	6
NATURAL GAS DATA (G25-25 mbar):							
Burner model	[-]	BS 2	BS 2	BS 3	BS 3	BS 3	BS 3
Burner type	[-]	912 T1	912 T1	913 T1	913 T1	913 T1	913 T1
Nominal load (lower value)	kW	60	75	90	115	135	175
Nominal power	kW	50.4	63	75.6	96.6	113.4	147
Pre-pressure	mbar	25	25	25	25	25	25
Burner pressure	mbar	4.6	7.1	3.5	5.1	6.2	11.4
Gas consumption *	m ³ /h	7.4	9.2	11.1	14.2	16.6	21.5
Heating up time $\Delta T = 45K$	min	20	16	13	9	8	6
PROPANE DATA (G30- 30 / 50- mbar):							
Burner model	[-]	BS 2	BS 2	BS 3	BS 3	BS 3	BS 3
Burner type	[-]	912 T1	912 T1	913 T1	913 T1	913 T1	913 T1
Nominal load (lower value)	kW	60	75	90	115	135	175
Nominal power	kW	50.4	63	75.6	96.6	113.4	147
Pre-pressure	mbar	30/50	30/50	30/50	30/50	30/50	30/50
Burner pressure	mbar	4.3	6.4	2.4	3.5	5.3	9.5
Gas consumption *	kg/h	4.7	5.9	7.1	9.1	10.7	13.8
PROPANE DATA (G31- 30 / 37/ 50- mbar):							
Burner model	[-]	BS 2	BS 2	BS 3	BS 3	BS 3	BS 3
Burner type	[-]	912 T1	912 T1	913 T1	913 T1	913 T1	913 T1
Nominal load (lower value)	kW	60	75	90	115	135	175
Nominal power	kW	50.4	63	75.6	96.6	113.4	147
Pre-pressure	mbar	30/37/50	30/37/50	30/37/50	30/37/50	30/37/50	30/37/50
Burner pressure	mbar	6.0	8.5	3.2	4.7	6.9	12
Gas consumption *	kg/h	4.7	5.8	7	8.9	10.5	13.6

* Gas consumption at 1013.25 mbar and 15°C

DESCRIPTION	Unit	COF 199	COF 245	COF 315	COF 385	COF 455	COF 700
OIL DATA							
Burner model	[-]	RG 2	RG 2	RG 3	RG 3	RG 3	RG 4S
Burner type	[-]	377 T1	377 T1	393 T1	393 T1	393 T1	396 T1
Nozzle (Delavan)	[-]	1.25x80W	1.5x80B	1.75x80B	2.25x80B	2.75x80B	4.0x80B
Nominal load (lower value)	kW	62.8	75.4	87.9	113	138	201
Nominal power	kW	52.3	63.3	73.9	95	116	168.8
Oil flow rate	kg/h	5.3	6.3	7.4	9.5	11.6	16.9
Pump pressure	bar	12	12	12	12	12	12
GENERAL							
Contents	litre	322	322	318	282	282	259
Number of anodes	-	2	2	2	3	3	4
Number of fire tubes	-	6	6	7	12	12	16
Cold water inlet	-	ISO-7 Rp 1½	ISO-7 Rp 1½	ISO-7 Rp 1½	ISO-7 Rp 1½	ISO-7 Rp 1½	ISO-7 Rp 1½
Hot water outlet	-	ISO-7 Rp 1½	ISO-7 Rp 1½	ISO-7 Rp 1½	ISO-7 Rp 1½	ISO-7 Rp 1½	ISO-7 Rp 1½
Drain valve	-	¼ - 14 NPT	¼ - 14 NPT	¼ - 14 NPT	¼ - 14 NPT	¼ - 14 NPT	¼ - 14 NPT
Anode	-	¼ - 14 NPT	¼ - 14 NPT	¼ - 14 NPT	¼ - 14 NPT	¼ - 14 NPT	¼ - 14 NPT
T & P connection	-	1 - 11.5 NPT	1 - 11.5 NPT	1 - 11.5 NPT	1 - 11.5 NPT	1 - 11.5 NPT	1 - 11.5 NPT
Maximum working pressure	bar	8	8	8	8	8	8
Weight (empty)	kg	260	260	260	290	290	335

1.3.4 Air-proving switch

This section is only applicable, if the heater has been equipped with a gas-fired burner.

The air-proving switch monitors the air flow to the burner during the pre-purge cycle and operating cycle of the water heater. If the air flow drops below a threshold value, the air-proving switch will measure an insufficient difference in pressure and will cut out. This causes the gas supply to the burner to be shut off immediately.

The switching point of the air-proving switch of Riello front-mounted burners is:

UNIT	Pressure difference for switching off [mbar]			
	GAS G20	GAS G25	GAS G30	GAS G31
COF 199	3,4	3,3	3,4	3,2
COF 245	5	5	5	5,3
COF 315	4,1	3,9	3,6	4,1
COF 385	5,5	5,5	5	5
COF 455	5,8	5,9	5,7	5,9
COF 700	6,2	6,2	6,3	6,5

The values above are recommended settings and have been determined under laboratory conditions. The air-proving switch's switching point must be set during the commissioning of the water heater. Please make sure that the air-proving switch cuts out before the CO contents of the flue gas reaches 2000 ppm.

This is checked by slowly closing the air supply and verifying that the burner controller locks before the CO contents of the flue gas reaches 2000 ppm.

1.3.5 Gas-pressure switch

This section is only applicable, if the heater has been equipped with a gas-fired burner.

The gas-pressure switch monitors the gas pre-pressure to the gas block. If the gas pre-pressure drops below a threshold value, the gas block will close-off the gas supply to the burner.

The switching point of the gas-pressure switch of Riello front-mounted burners is:

UNIT	Switching point gas-pressure switch [mbar]			
	GAS G20	GAS G25	GAS G30	GAS G31
COF 199	6	6	6	6
COF 245	6	6	6	6
COF 315	7	7	7	7
COF 385	7	8	6	6
COF 455	8	8	5	6
COF 700	10	12	7	7

The values above are recommended settings and have been determined under laboratory conditions.

The gas-pressure switch's switching point must be set during the commissioning of the water heater. Please make sure that the burner safely extinguishes before the CO contents of the flue gas reaches 2000 ppm.

This is checked by slowly closing the gas supply and verifying that the burner controller safely locks before the CO contents of the flue gas reaches 2000 ppm.

1.3.6 Setting the burner head

This section is applicable for heaters equipped with either gas-fired burners or oil-fired burners.

The burner head is set as a function of the water heater's required flow rate. During the commissioning of the water heater, the position of the burner head must be set to the value stated in the table below. Please also refer to the burner's instruction manual.

The setting of the burner head for Riello front-mounted burners is as follows:

UNIT	Notch number ... in burner head				
	Gas-fired burner				Oil-fired burner
	GAS G20	GAS G25	GAS G30	GAS G31	
COF 199	2	2	2	2	2
COF 245	3	3	3	3	3
COF 315	2.3	2.3	1.5	15	3
COF 385	3	3	3	3	3
COF 455	4.3	4.3	4.3	4.3	4
COF 700	7	7	7	7	4

1.3.7 Setting the air valve

This section is applicable for heaters equipped with either gas-fired burners or oil-fired burners.

The air valve is set as a function of the water heater's required flow rate. During the commissioning of the water heater, the position of the air valve must be set to the value stated in the table below. Please refer also to the burner's instruction manual.

The setting of the air valve for Riello front-mounted burners is as follows:

UNIT	Notch number ... in burner head				
	Gas-fired burner				Oil-fired burner
	GAS G20	GAS G25	GAS G30	GAS G31	
COF 199	1.6	1.7	1.9	1.6	2.4
COF 245	2.1	2.5	2.3	2.1	3.5
COF 315	1.9	1.8	1.5	1.5	1.7
COF 385	2.9	2.9	2.5	2.5	2.7
COF 455	3.1	3.1	3	3	3
COF 700	5.2	5	4.2	4.2	3.5

The values above are recommended settings and have been determined under laboratory conditions. Make sure that the CO₂ figure is lower than 10% for G20 and G25, and lower than 12% for G30 and G31. A maximum CO₂ figure of 12.5% applies to oil. If the CO₂ figure does not meet the requirements after the air valve has been set, the latter must be readjusted.

2. FOR THE INSTALLER

If possible, use a trolley or fork-lift truck to transport the heater. The heater must be vertical at all times during transportation. The installer must ensure that the required combustion air intake is not located in areas where chemical substances are stored and/or used. Some propellants, bleaches, degreasing substances and the like, give off vapours which cause accelerated corrosion. If the heater is used in areas where such substances are present, the guarantee is null and void.

2.1 Installation procedure

This water heater must be fitted in a location which will permit the provision of an approved flue system and adequate ventilation. The water heater must stand on a level surface resistant to heat and with sufficient strength to support the weight of the unit when full of water. This water heater must not be installed in a bath room, bedroom or in a cupboard opening on to such rooms.

This water heater must not be installed in any area where flammable materials are used or stored. Insufficient ventilation may give rise to a risk of fire, explosion or suffocation. If in doubt consult the national and local regulations governing the installation of gas appliances or your local British gas service department.

2.1.1 Installation

These water heaters must be installed by a qualified competent installer, in accordance with the following standards and regulations:

- Gas safety (installation and use) regulations 1944.
 - BS 5440 part 1 1990;
 - BS 5440 part 2 1989.
- Installation should be carried out in accordance with all local authority and building regulations, local water authority and fire regulations and the following British standards: British Gas Publication UP1 and UP2.
 - BS 5482 part 1 1979;
 - BS 5482 part 2 1979;
 - BS 5482 part 3 1979;
 - BS 6644;
 - BS 6700;
 - BS 6798.
- Some chemicals produce vapours which can cause rapid failure of thermocouples, burners and storage tanks if they are drawn into the combustion air supply. Therefore if this water heater will be used to supply hot water to:
 - Hairdressers;
 - Dry cleaners;
 - Industrial degreasing processes;
 - Any other area where compounds containing halogens are used and stored. Care should be taken that all primary and ;
 - secondary air is drawn from outside atmosphere free of such contaminants.

For further advise contact A.O.Smith.

2.1.2 Water connections

A.O. Smith water heaters are suitable for connection to vented, unvented and pumped pressurised systems. In each case appropriate valves and fittings should be used to ensure the system complies with the requirements of the water by laws, and appropriate building regulations.

When fitting it is essential the rules of 'good practice' are applied at all stages of installation.

2.1.2.1 Vented systems

If the water heater is to be connected to a cold feed tank or cistern the hot water supply pipe must include an open vent which discharges over the cold feed cistern. The cold feed cistern must have an actual capacity of greater volume than the hourly recovery rate of the water heater(s) which it supplies. The minimum actual capacity is 50 gallons or 227 litres (see figure 3).

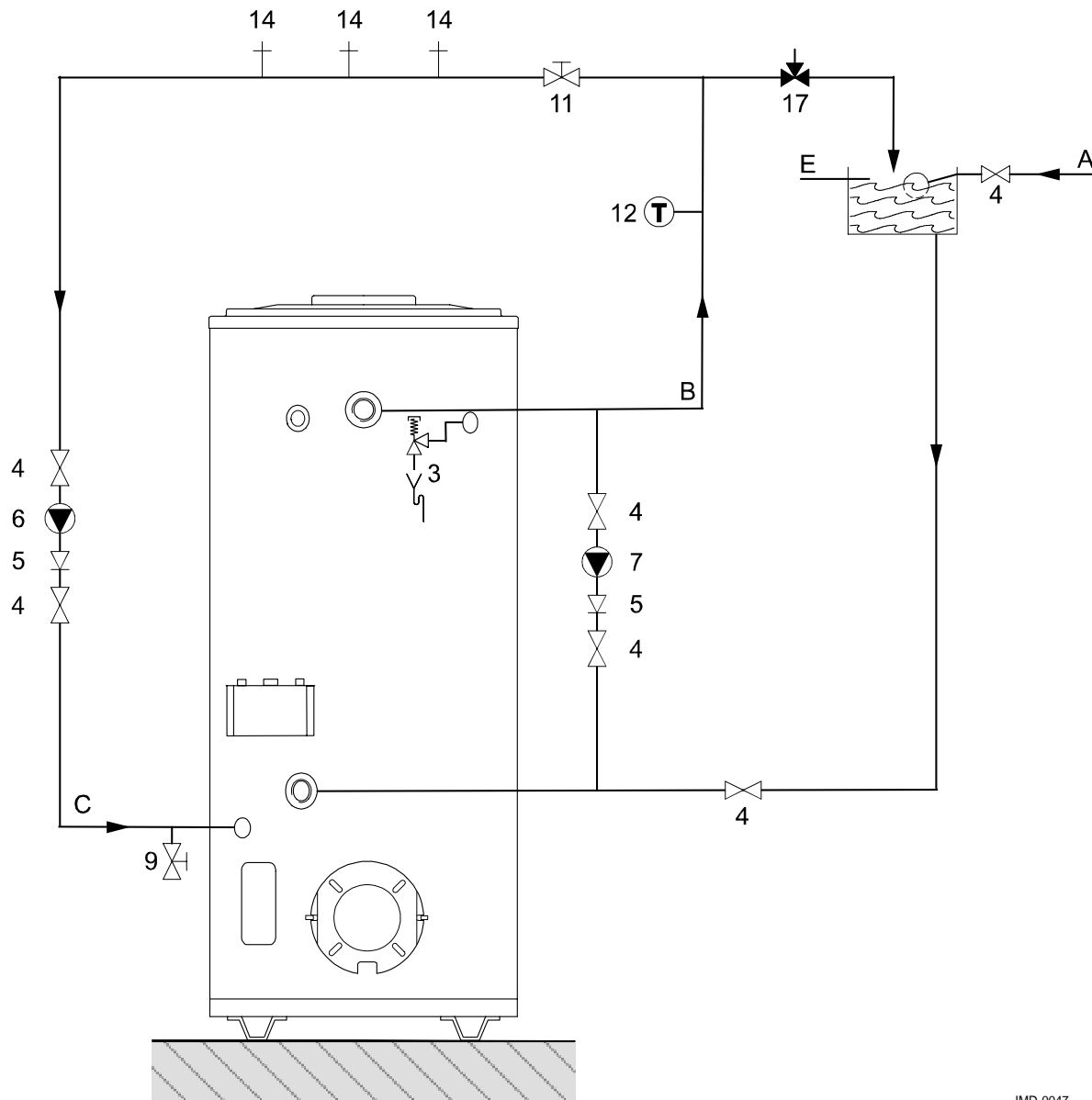

IMD-0047

Figure 3 - Typical UK vented system

- | | |
|-----------------------|--------------------------|
| 3) T&P valve | 14) Hot water supply |
| 4) Stop valve | 17) Three way vent valve |
| 5) Non return valve | A) Cold water |
| 6) Circulation pump | B) Hot water |
| 7) Shunt pump | C) Return circulation |
| 9) Drain valve | E) Overflow |
| 11) Service valve | |
| 12) Temperature meter | |

2.1.2.2 Unvented systems

To install an A.O. Smith water heater on an unvented cold water supply system a kit of valves and fittings listed by the water research centre and complying with part G3 of the current building regulations and BS 7206 should be used. Installation should be carried out generally as shown on figure 4.

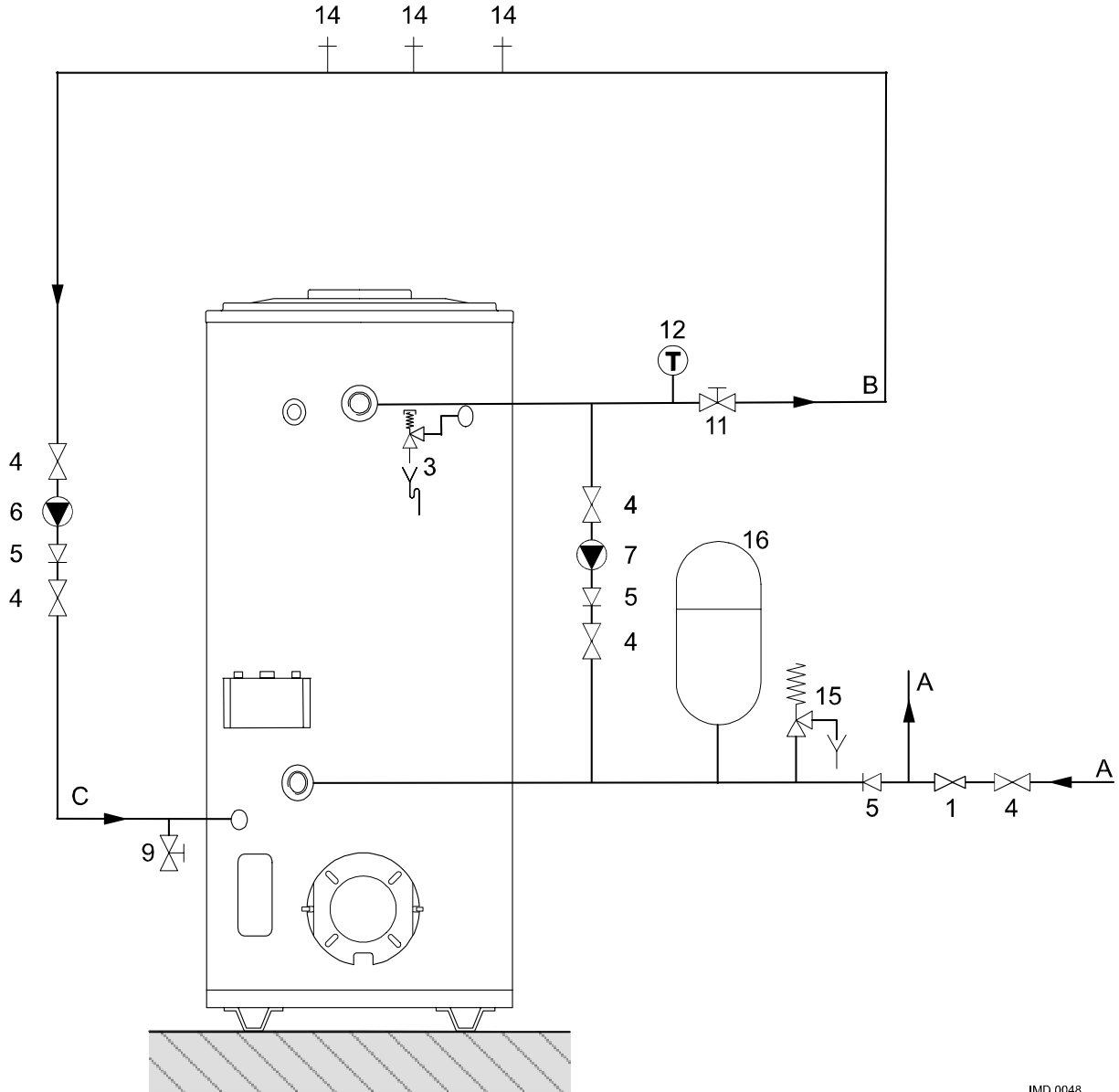

IMD 0048

Figure 4 - Typical UK unvented system.

- | | |
|----------------------------|-----------------------|
| 1) Pressure limiting valve | 12) Temperature meter |
| 3) T&P valve | 14) Hot water supply |
| 4) Stop valve | 15) Expansion valve |
| 5) Non return valve | 16) Expansion vessel |
| 6) Circulation pump | A) Cold water |
| 7) Shunt pump | B) Hot water |
| 9) Drain valve | C) Return circulation |
| 11) Service valve | |

A.O. Smith water heaters are tested to a maximum pressure of 12 bar and a maximum working pressure of 8 bar.

Dead legs on a hot water installation are undesirable. Where possible they should be avoided. Where the inclusion on the system of a dead leg is unavoidable the following restrictions should be applied:

- For pipes not exceeding 19 mm. inside diameter; maximum length of dead leg permitted 12.0 metres;
- For pipes exceeding 19 mm. but not exceeding 25 mm. inside diameter; maximum length of dead leg 7.5 metres;
- For pipes with an inside diameter exceeding 25 mm. maximum dead leg 3.0 metres.

Depending on the length and insulation of the water piping and the water demand frequency, it may be necessary to install a circulation system on the drain valve. The return pipe of the circulation piping can be fitted on top of the drain valve after the sealing plug has been removed (see figure 5)

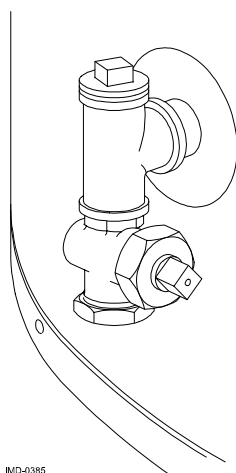

Figure 5 – Connection point for the return piping

Depending on the water demand pattern (e.g., small amounts frequently), it may be necessary to circulate the water in the heater to prevent temperature stratification. Therefore, we recommend that a circulation system is installed in the event of such demand patterns (see figure 3 or 4).

2.1.3 Gas connection

The gas supply to this appliance must be installed in accordance with BS 6891 (1988) and British Gas Publications UP1 and UP2. No heat or soldered joints should be applied in the vicinity of the gas control, as they could cause damage to the control. All connections and joints should be tested for gas soundness with a suitable leak detector (do not use a naked flame). When operating this unit on LPG a suitable gas supply cock should be used.

2.1.4 Flue gas exhaust

For the COF 199 and 700 the adapter ring supplied must be fitted prior to connecting the flue gas exhaust. For the other models (COF 245, 315, 385, 455 and 700) the flue gas exhaust can be connected direct to the water heater. The flue pipe, which is protected against corrosion, must at least have the same diameter as the mounting flange on the water heater. For units with an oil-fired burner, a stainless steel flue pipe must be installed.

The following diameters of flue gas exhaust pipes apply:

UNIT	Diameter flue gas exhaust pipe [mm]
COF 199	150
COF 245	200
COF 315	200
COF 385	200
COF 455	200
COF 700	250

2.1.5 Burner connection

For connecting the ventilator burner, please refer to the instructions supplied with the burner.

Read these instructions carefully before attempting to install and connect the burner.

2.1.6 Electrical connection

All electrical connections must be carried out in accordance with IEE regulations by an accredited electrical installation company.

The control box must be connected to the mains by means of a permanent electrical connection. A bipolar main switch with a contact opening of at least 3 mm must be fitted between this permanent connection and the heater.

The supply cable must have cores of at least 3 x 1.0 mm². The connecting clamps for the supply voltage are located on the connector strip in the control box. Always check with a voltage tester if the live and the neutral have indeed been connected correctly in the control box. This is essential for the functioning of the ventilator burner's flame detection.

The electricity supply must comply with the requirements below:

Supply voltage	Frequency	Fuse
230 V AC (-15% / +10%)	50 Hz (+/- 2%)	6 A

The electrical diagrams of all connections in the control box are shown in the appendix, (see figure 9: Electrical diagram).

2.2 Commissioning

2.2.1 Filling the heater

1. Fit drain valve and check that it is closed.
2. Open the cold-water tap to the heater and all hot-water outlets in order to remove all air from the system. The heater has been filled when cold water runs out at all outlets.
3. Close all taps at the hot water draining points. The heater is now under water mains pressure. At this pressure, which can be read on a manometer, the relief valve must not release any water.

2.2.2 Turning on the burner

The burner must be turned on in accordance with the installation manual supplied with the front-mounted burner.

2.3 Shutting down

For brief periods:

1. Turn the temperature control knob fully clockwise (up to 40°C) and set the 'I/O' switch to '0'.

For longer periods:

1. Switch off the supply voltage by operating the bipolar main switch;
2. Close the inlet gas valve;
3. Close the water inlet tap;
4. Empty the heater to prevent frost damage.

2.4 Usage / temperature control

The water temperature is controlled by the control box on the heater. If the temperature in the water heater drops below the set value, the control box will send a voltage signal to the ventilator burner. The burner automation of the ventilator burner will then ignite the burner and keep it burning until the control box ceases to supply voltage signals.

The desired water temperature can be set between 40°C and 80°C. High water temperatures cause more calcium precipitation in the water heater. Moreover, the stand-by losses of the water heater are greater with higher temperatures. Therefore, it is recommended to set the control thermostat to approx. 60°C.

For reasons of safety, the water heater is equipped with a high-limit thermostat and an overheating cut-out. If the high-limit thermostat is activated, the heater is not locked and the control thermostat will take over the temperature

control again as soon as the high-limit thermostat is deactivated.
 If the overheating cut-out is activated, it must be reset manually after the water has cooled down. Upon resetting, the water heater will resume its operation in the usual way.

2.5 Setting the nominal load

This section is only applicable, if the heater has been equipped with a gas-fired burner.

Setting the nominal load is always necessary because the load may vary with the various ventilator burners. The burners have not yet been set to the right load by the manufacturer.

Setting the nominal load and checking the correct gas/air ratio must be carried out in accordance with the instruction manual for the front-mounted burner. The burner pressures to be set for Riello front-mounted burners are shown in table 1.3.2

2.6 Conversion to another gas type

This section is only applicable, if the heater has been equipped with a gas-fired burner and conversion of the burner is permissible.

If the heater has to function on a gas category (LP-gas or natural gas) other than the gas set as standard (ex works), the heater must be converted to the applicable gas category by means of the conversion kit(s) to be ordered. Only an authorised installer may convert the heater.

2.7 Maintenance

The heater must be checked and cleaned regularly (at least once a year) by an accredited installer, so that correct operation is guaranteed. The bar burners, control and safety valves, the glow igniter and anodes must also be checked.

2.8 Anode

The life of the anode is determined by the quality and quantity of the water flowing through the heater. Therefore, we recommend that the anode is checked regularly - preferably simultaneously with an internal inspection of the glass lined tank. In order to determine the frequency with which the anodes must be replaced, the water side of the boiler must be checked three months after installation. The anodes must be replaced if more than 60% has dissolved at any point on their length.

To inspect the tank:

1. Close the cold-water inlet tap;
2. Empty the heater completely by opening the drain valve;
3. Remove the covering plates on the heater's outer jacket;
4. Remove the access cover plates from the tank by unscrewing and removing the bolts and washers, (see figure 6);
5. To ensure watertightness of the access covers the rubber O-rings must be replaced when the access covers are refitted, (see figure 6).

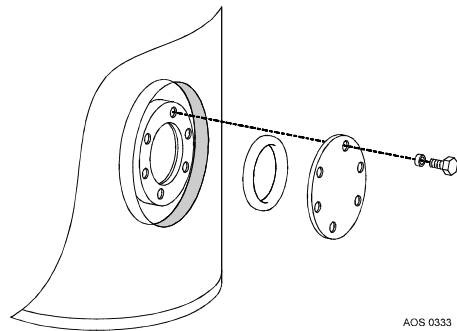

Figure 6: Inspection hatches.

To inspect the anodes:

1. Remove the draught diverter;
2. Unscrew the fastening screws on the lid edge;
3. Remove the lid. The hexagonal heads of the anodes are now visible, (see figure 7);
4. Unscrew the anodes with the appropriate spanner and replace with new anodes if required. Attention: the anodes must make contact with the tank (metal on metal). If the tank and the anodes are separated electrically (as a result of the sealing material used), the anode cannot function. This could have a negative effect on the operating life of the tank;
5. Assemble everything in reverse order;
6. Fill the heater and test.

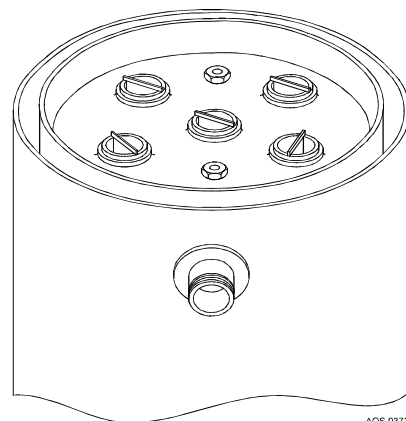

Figure 7: Anodes

2.9 Descaling

Calcium deposition depends on the type of water and the demand. In addition, calcium deposition increases at high water temperatures. A temperature setting of 60°C is recommended, which will keep calcium deposition to a minimum.

Access covers are located on the right and left sides for inspecting and descaling the tank. The access covers can be reached via the covering plates on the outer jacket.

Empty the heater before opening the access covers. Descaling must be carried out with a suitable substance. Consult the supplier or installer.

2.10 Condensation

When the heater is filled with cold water or the hot-water consumption is very high, the flue-gases will condense on the cold surfaces of the combustion chamber and the flue-gas discharge pipes. The drops of water will fall on the burner and cause a hissing sound. This is normal and will stop as soon as the operating temperature has been reached.

2.11 Spare parts

It is important to mention the heater, type, model and full serial number when ordering spare parts. The spare parts can be determined according to these numbers.

3. FOR THE USER

3.1 Instructions for use

3.1.1 Lighting the heater

WARNING:

An accredited installer must install the heater and commission it.

3.1.2 Filling the heater

1. Fit the drain cock and check that it is closed.
2. Open the cold-water tap to the heater and all hot-water outlets in order to remove all air from the system. The heater has been filled when cold water runs out of all outlets.
3. Close all the hot-water taps. The heater is now under pressure.

3.1.3 Commissioning

1. Check that the heater is filled with water and that the gas supply to the heater is on;
2. Turn the temperature dial clockwise as far as it will go;
3. Switch the supply voltage on by operating the bipolar main switch.
4. Set the 'I/O' switch on the control box to 'I'.
5. Turn the temperature control knob to the desired position, preferably to approx. 60°C. The ventilator burner will now ignite.

3.2 Operation

The water temperature is controlled by the control thermostat in the control box on the column. If the temperature in the water heater drops below the set value, the control will send a voltage signal to the ventilator burner. The burner automation of the ventilator burner will then ignite the burner and keep it burning until the control ceases to supply voltage signals.

High water temperatures cause more calcium precipitation in the water heater. Moreover, the stand-by losses of the water heater are greater with higher water temperatures.

Therefore, it is recommended to set the control thermostat to approx. 60°C

For reasons of safety, the water heater is equipped with a high-limit thermostat and an overheating cut-out. If the high-limit thermostat is activated, the heater is not locked and the control thermostat will take over the temperature control again as soon as the high-limit thermostat is deactivated.

If the overheating cut-out is activated, it must be reset manually after the water has cooled down.

Upon resetting, the water heater will resume its operation in the usual way.

3.3 Shutting down

For brief periods:

1. Turn the temperature control knob fully clockwise and set the 'I/O' switch to 'O'.

For longer periods:

1. Switch off the supply voltage (operate bipolar main switch).
2. Close the inlet gas valve;
3. Close the water supply tap.
4. Empty the heater to prevent frost damage.

3.4 Maintenance

Maintenance should be carried out at least once a year in accordance with the recommendations of A.O. Smith.

Failure to carry out adequate maintenance may render the warranty void. We recommend that you take out a maintenance contract with your installer.

4. WHAT TO DO IN CASE OF FAILURE

4.1 General

If faults occur, check the following points:

- **Overheat thermostat**
The water heaters are equipped with an overheating cut-out, which, in the case of a too high water temperature, interrupts the current supply to the burner, as a result of which the gas valves in the gas block are closed and the gas supply is cut off. The overheating cut-out remains activated until the water temperature drops below the overheating cut-out's switching-off point. Then the water heater can be turned on again by resetting the overheating cut-out. Next set the control thermostat to a lower water temperature, (see figure 8).
- **Water temperature too high:**
Check if the control thermostat has been set too high.
- **Wrong hot water temperature:**
 1. Check the control thermostat setting;
 2. Check that there are no leaks or if any taps are open.

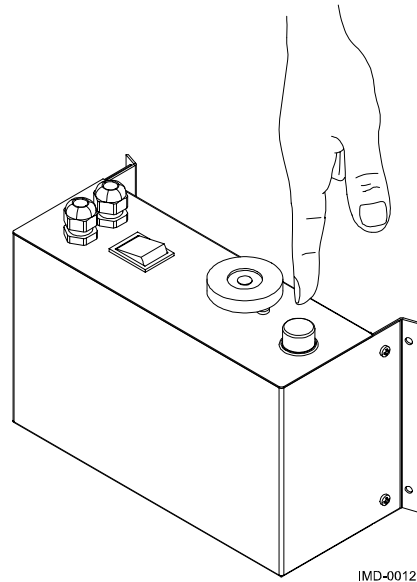

Figure 8: Resetting the overheating cut-out

4.2 Fault overview

Fault	Possible cause	Measure
Heater is off or does not ignite	Chimney is blocked.	Trace (or let trace) cause and rectify it.
	Overheating cut-out is activated.	Let water in heater cool down and set the water temperature to a lower value. Reset the overheating cut-out. Let heater ignite.
	Gas or oil supply shut off.	Open gas or oil valve.
Insufficient hot water or none at all	Temperature set too low.	Set water temperature to higher value.
	Overheating cut-out is activated.	Reset overheating cut-out after the water has cooled down and set the water temperature to a lower value.
	Supply of hot water exhausted.	Reduce hot water use. Give the heater time to heat up the water.
	Cause cannot be traced.	Remove voltage supply. Close gas / oil supply valve and contact your installer.
Water leakage	Insufficient sealing of the water connections (screw thread).	Tighten the screw thread connections.
	Leakage from another water appliance or pipes in neighbourhood.	Trace the cause.

Please consult the front-mounted burner's installation manual in the event of faults in the front-mounted burner.

5. WARRANTY

The following conditions form the guarantee agreement between A.O. Smith Water Products Company (the warrantor) and the owner of the water heater.

5.1 Guarantee in general

If within one year of the original installation date of the water heater any part or component other than the tank shall prove upon examination by the warrantor or authorised agent to be defective in material or workmanship, the warrantor will exchange such part or component.

5.2 Guarantee of the tank

If within 3 years of the original installation date, the tank fails due to rust or corrosion from the water side, the warrantor will supply a complete new water heater of equivalent size and duty (excluding delivery and installation charges). On the replacement water heater a guarantee will be granted sufficient to cover the unexpired portion of the original 3 year guarantee of the originally installed water heater.

5.3 Conditions for installation and use

The guarantee applies to the heater only while it remains in its original location, and is installed in accordance with the local plumbing and building regulations and all relevant Codes of Practice.

The water heater should also have been used only:

- a) For potable water free to circulate at all times and with the tank free of damaging scale deposits;
- b) At temperatures not exceeding the maximum setting of its thermostat and ECO (Energy Cut Off device);
- c) At water pressures and/or energy inputs which do not exceed those stated on the rating plate of the water heater;
- d) In a non corrosive atmosphere or area;
- e) With an approved temperature and pressure relief valve of adequate capacity not exceeding the working pressure rating shown on the water heater, and installed in conformity with A.O. Smith Water Products Companies installation instructions;
- f) When anodes have been inspected and renewed, if they are worn or eroded by 50% or more at any point of their length.

5.4 Exclusions

The guarantee will be null and void:

- a) If the water heater has been damaged by an external cause;
- b) In case of misuse, neglect (including frost damage) or incorrect use of the water heater;
- c) In case of unauthorised alteration, modification or repair;
- d) In case of ingress into the water heater of chemicals, pollutants or contaminants;

- e) If the hardness of the incoming water is, or has been, softened below 60 ppm CaCO_3 ;
- f) If the water heater is effected by corrosive vapours such as those found in hairdressers, dry cleaners and laundries or where some industrial degreasing products are used and stored (for further information and advise please contact the A.O. Smith Technical Department).

5.5 Range of guarantee

All replacement water heaters supplied under the terms of this warranty will be supplied ex stock on an F.O.B. basis. A.O. Smith accepts no responsibility for carriage, labour or other installation costs.

5.6 Claims

Any claim under this warranty should be initiated with the dealer who originally sold the water heater or with any other dealer or stockist of the warrantors products.

5.7 No other guarantee or warranty either expressed or implied is made on behalf of A.O. Smith Water Products Company.

With respect to the water heater in question further A.O. Smith does not guarantee this water heater as suitable for purpose except within the terms of warranty detailed above. A.O. Smith Water Products Company will not be liable by virtue of this guarantee or otherwise for damage to any persons or property when arising out of contracts or tort. The terms of this guarantee do not effect your statutory rights under United Kingdom Consumer Legislation.

This guarantee applies to the following models:
COF 199 G t/m 700 G

6. Appendix:

6.1 Electrical diagram cof

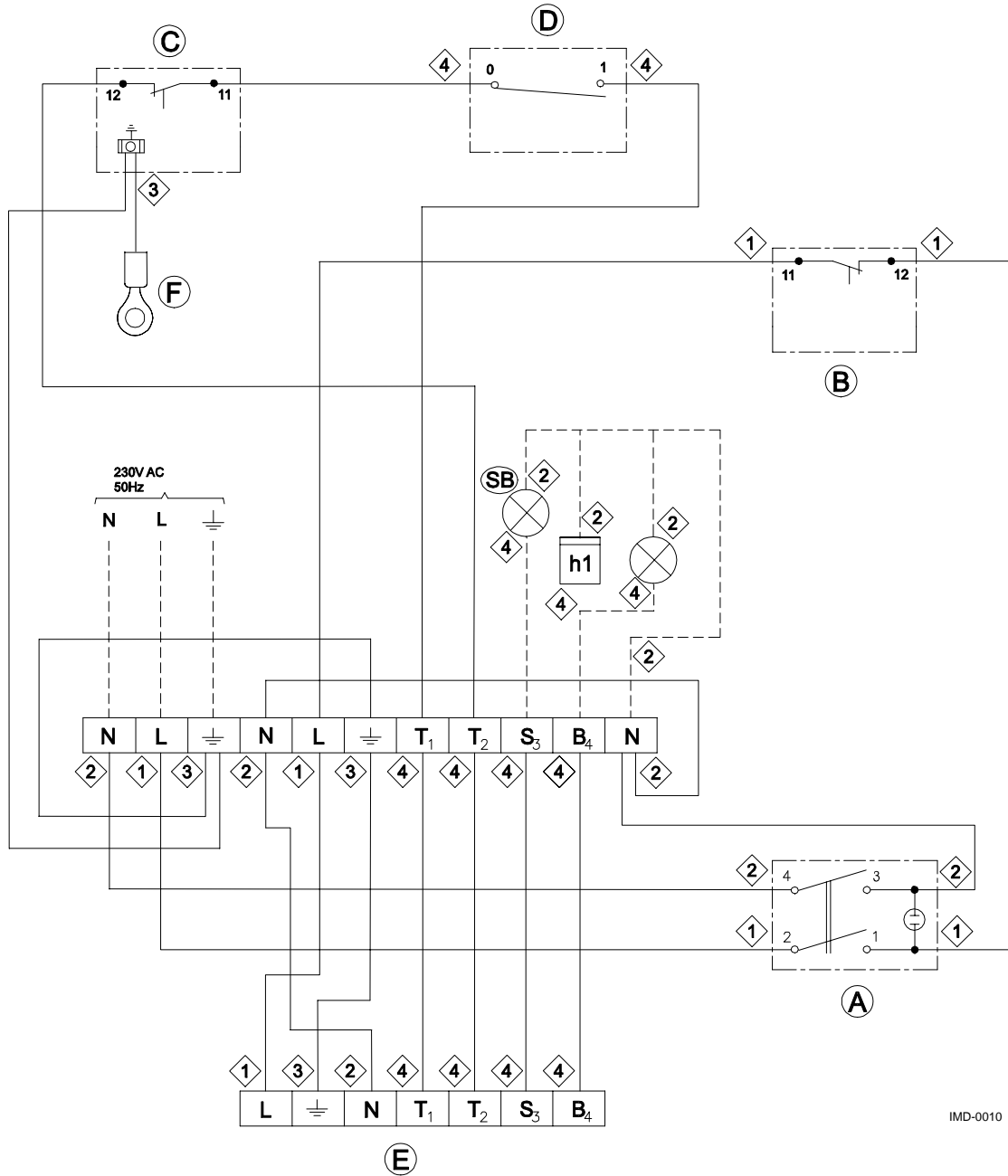

IMD-0010

Figure 9: Electrical diagram cof

- ① = brown
- ② = blue
- ③ = yellow/green
- ④ = black

- ⊥ = Earth
- N = Neutral
- L = Live

- A = 'I/O'-switch
- B = Overheating cut-out
- C = High-limit thermostat
- D = Control thermostat
- E = Male 7-pole connector

- H1 = Running time counter
- SB = Fault alarm

Note:

If, in the case of a Riello front-mounted burner, a running time counter (H1) is connected by means of a cable longer than 3 m, a 47 nF capacitor must be fitted between B4 and earth to prevent EMI.

The same applies to the installation of a fault alarm (SB); in this case a 100 nF capacitor must be fitted between S3 and earth, if the cable length exceeds 3 m.

